



**26 Ward Hill Ave., Bradford, MA 01835
Phone: 978-241-8260 Fax: 978-241-8262**

USER MANUAL HPP-6000-XX-YY-ZZ

**XX = Ioutmax
YY = Maximum Compliance Voltage
ZZ = Max Pulse Width in μ sec**



Table of Contents

1. Warnings.....	3
2. Description of HPP System.....	4
3. Pulsing Characteristics	5
4. DC power supply for HPP.....	7
5. Supply Interface Connections.....	8
6. LDD/HPP integration and theory of operation.....	9
7. LDD with HP option.....	12
8. LDN with VP option.....	13
9. HPP-6000 Specifications.....	13
10. HPP Interface.....	15
11. Operation of the HPP.....	16
12. Product Limited Warranty.....	24
13. Service.....	25

Tables and Figures

Table 1, HPP Interface.....	15
Figure 1, HPP Block Diagram.....	4
Figure 2, Typical Rise Time.....	5
Figure 3, Typical Fall Time.....	5
Figure 4, Pulse Output.....	6
Figure 5, Repetition Rate.....	6
Figure 6, Connection Diagram.....	8
Figure 7, Good setting with 2V across the regulator at the end of the pulse.....	11
Figure 8, Good setting with 2V across the regulator at the end of the pulse.....	18
Figure 9, Good Pulse Train Stable Operation at 100A output, 90V input.....	18
Figure 10, Buss voltage set too high,.....	19
Figure 11, Buss voltage set too high,.....	20
Figure 12, Buss voltage set too low.....	20
Figure 13, Buss voltage extremely low,.....	21
Figure 14, HPP Mechanical Outline Drawing.....	22
Figure 15, HPP Connections.....	23

1. Warnings

Warning – Output Floating

Do not connect the HPP output or laser diode load to any ground, it must remain floating, or serious damage to the power supply and laser diode will occur!

The output of the HPP is floating and therefore, neither side of the laser diode must be connected to the same ground as signal ground (Program, Monitor).

Warning – Output Floating

Do not connect an oscilloscope or any instrumentation directly to the laser diode load! Only floating measurements can be used such as a differential voltage probe and Hall Effect current sensors.

Warning – Voltage Compliance Requirement

Each HPP is custom configured to deliver current pulses into a diode array requiring a predefined compliance voltage. See the Serial Number label of the unit for the compliance voltage rating. The HPP takes DC input voltage and will not operate properly when the input is great than 10V higher than the load compliance voltage and will not start when the input is 20V lower than the rating on the S/N label or lower than 20V. Consult factory more wider operating window.

WARNING: Only Lumina Power, Inc. qualified service personnel are allowed to remove the covers and service this equipment.

WARNING: NEVER OPERATE THE POWER SUPPLY:

1. Without providing adequate protection of personnel from high voltage.
2. Without proper ground connections.
3. Without covers and panels properly installed.
4. Without a suitable load for the application and properly rated for the required power dissipation.

2. Description of HPP System

Warning – Output Floating

Do not connect the HPP output or laser diode load to any ground, it must remain floating, or serious damage to the power supply and laser diode will occur!

The output of the HPP is floating and therefore, neither side of the laser diode must be connected to the same ground as signal ground (Program, Monitor).

Lumina Power's HPP power supplies are designed for pulsing diode lasers in Quasi-CW applications. Before operating this unit, it is important to understand the operation. A block diagram of the power supply is shown below.

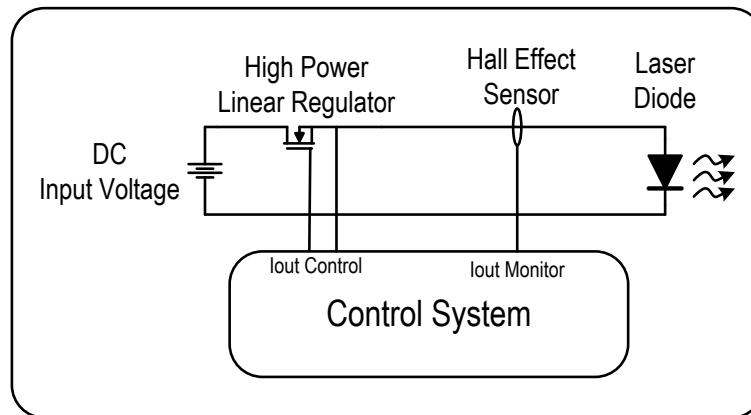

Figure 1, HPP Block Diagram

Referring to Figure 1, the basic elements of the HPP system is a high power linear regulator. The four main components are:

- A **storage capacitor, which** holds the energy for a high power pulse.
- A **high power linear regulator**, which is controlled by an error signal.
- A **high current sensing circuit**.
- The **control system**.

The **DC input voltage** source must be voltage programmable and have current limit but not current fold-back. It must be able to deliver constant current into a big capacitor which is a short at start up and the voltage will be discharged to a low level at the end of every pulse. Set the output voltage at 2 to 5V higher than the load compliance voltage for optimal efficiency.

Even though the HPP output current has better than 15us rise/fall time, the compliance voltage is only a few volts higher than the load voltage and the LDD-xx-yy-HP will perform this requirement automatically.

The **high power linear** regulator is typically a bank of high power MOSFETS mounted on an appropriate heat sink with over-temp protection.

The **control system** provides the interface to the supply and provides various protection circuits for the laser diode.

3. Pulsing Characteristics

The rise and fall times of HPP pulses are a compromise between speed and minimization of overshoot. The following figures show typical pulse performance for a HPP with 300Apeak output. In each of the figures, the oscilloscope traces are

- Channel 1: Output Current. 100Amp/V
- Channel 2: Pulse Command Signal
- Channel 3: Current Monitor

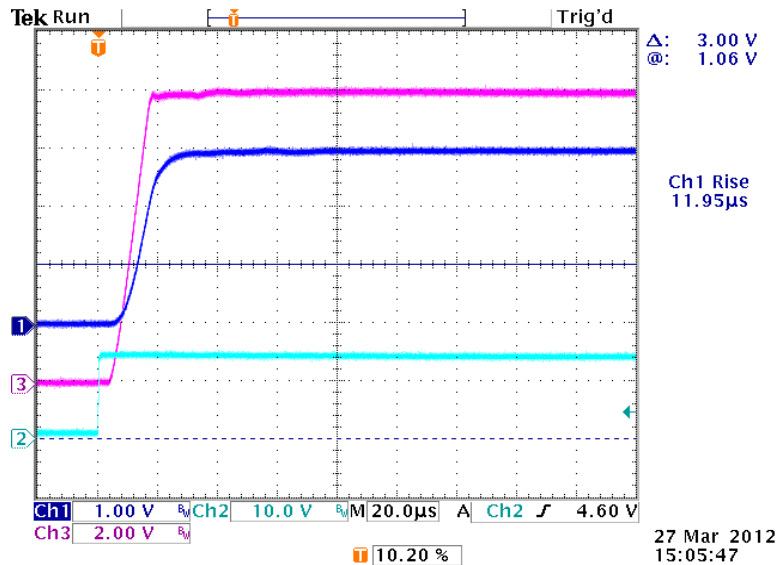

Figure 2, Typical Rise Time

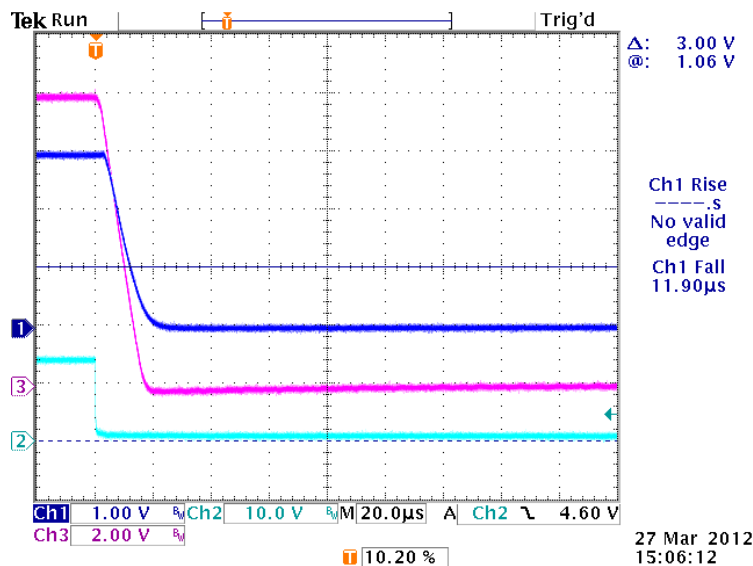

Figure 3, Typical Fall Time

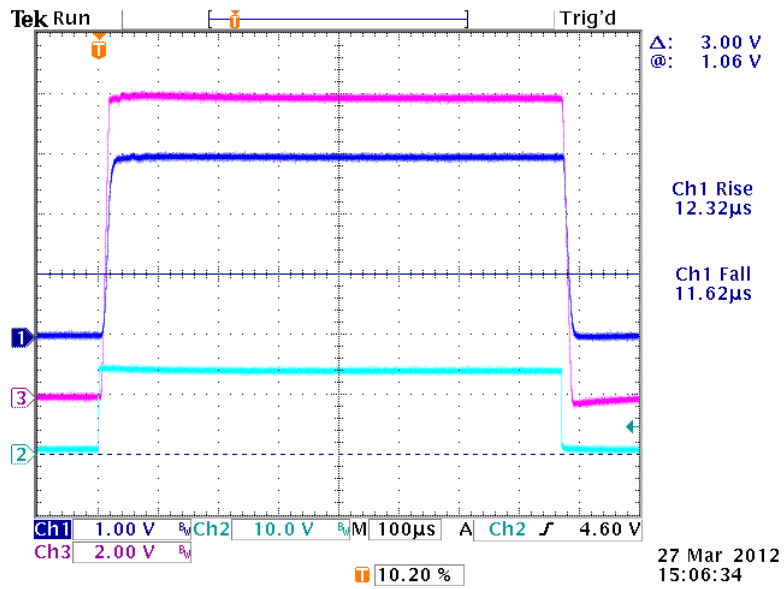

Figure 4, Pulse Output

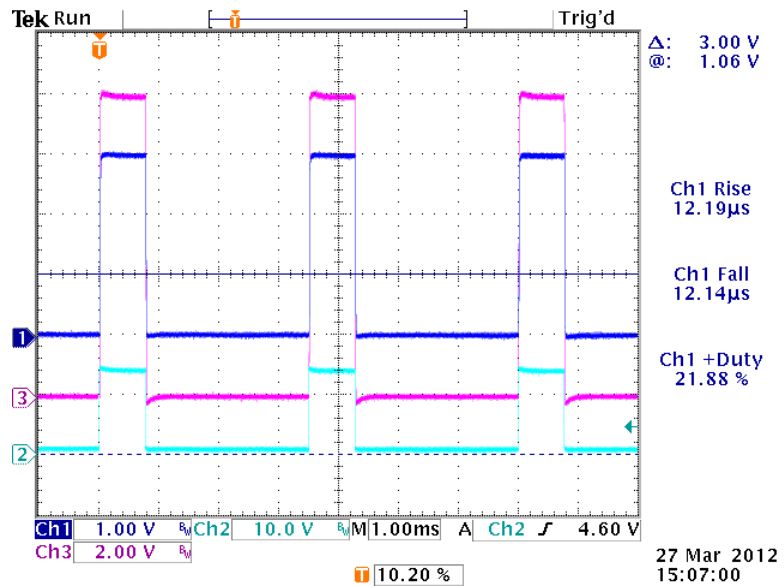

Figure 5, Repetition Rate

4.DC power supply for HPP

The HPP can be driven by any DC power source without current fold-back.

When the HPP is on, it will draw high current from the DC source which should send continuous limited current to the HPP and should not fold back because the HPP needs certain input voltage to operate.

It is recommended to use LDN-2000, LDD-3000 or LDD-6000 with a HP option to drive the HPP.

The LDN-2000/LDD-3000/6000-xx-yy-HP is configured to run with the HPP. Output voltage can be set to match the laser load and output current can be set to meet the max average load current.

Besides, the LDN-2000/LDD-3000/6000-xx-yy-HP interfaces with the HPP to regulate the output voltage to perfectly match the load voltage for the highest efficiency and least heat dissipation inside the HPP.

5. Supply Interface Connections

Warning – Output Floating

Do not connect the HPP output or laser diode load to any ground, it must remain floating, or serious damage to the power supply and laser diode will occur!

The output of the HPP is floating and therefore, neither side of the laser diode must be connected to the same ground as signal ground (Program, Monitor).

The programming, monitoring, and control functions of the HPP Interface are shown below. Refer to Figure 6 below for a simple laser setup.

Due to high switching current at high frequency and the capacitive coupling from the laser diodes to heatsinks, a ground loop is usually hard to avoid and interferes with the pulse current. An isolator board has been designed to use in series with the interface cable of the HPP to break the ground loop.

Please refer to document 33001346, HPP-LDD Interconnection Instructions.

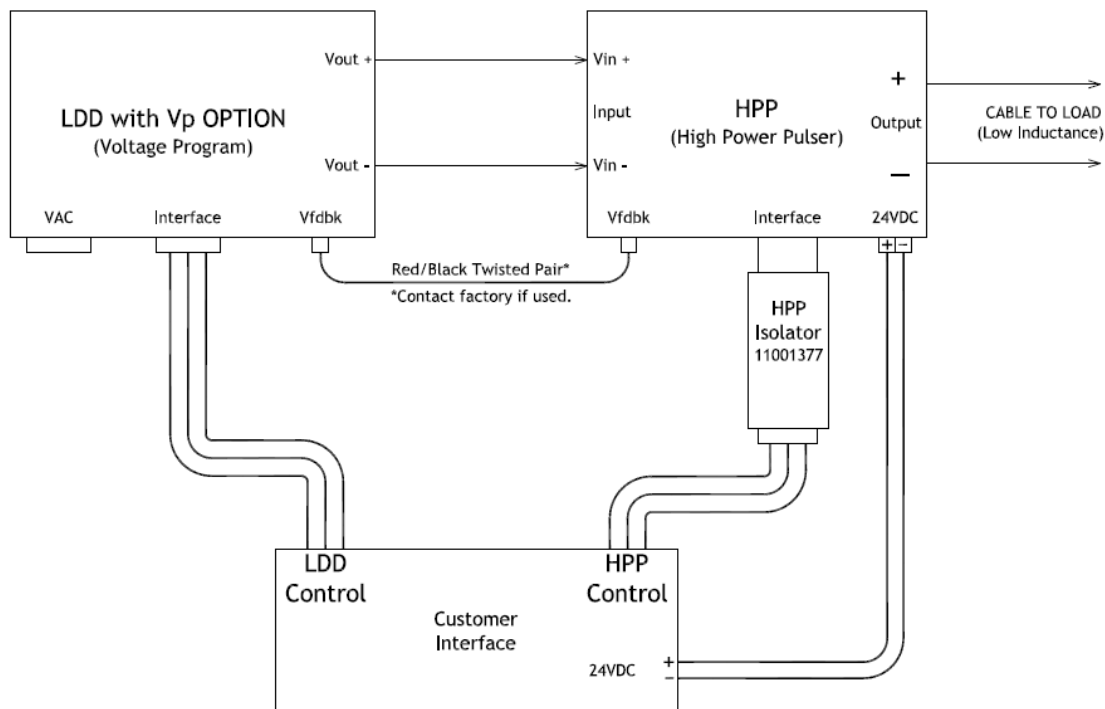

Figure 6, Connection Diagram

* Note, the voltage control feedback is only available when using LDN-2000/LDD-3000/6000 with the HP option.

6.LDD/HPP integration and theory of operation

The HPP was designed to work with Lumina Power's LDD power supplies with the HP option, which is the output voltage programmable feature.

The complete system includes:

- 1 LDD-pp-xx-yy-HP where pp is max power, xx is max current, yy is max output voltage and HP designates output voltage program feature.
- 2 HPP-pp-xx-yy-zz. pp is maximum average power, xx is maximum output current, yy is maximum load voltage, zz is maximum pulse width up to CW.
- 3 HPP Isolator PCB. Due to possible ground loops at high pulsing current and frequency, the isolator PCB will be inserted between the HPP and the customers' control system to break the ground loop.

Isolator PCB theory of operation:

The Isolator has two electrically isolated sections: one is connected to the HPP and another is connected to the customer's control system.

The HPP supplies 15V to operate the isolator pc board. The customer's control system **must supply 15V** to run the section that is connected to the customer's controller per HPP pin out assignment.

The Isolator carries all control signals through linear optocouplers for analog signals and logic optocouplers for logic signals. The pin outs of the isolator PCB is 1-to-1 as an extension of the control cable with a male connector for the customer's controller and a female connector for the HPP.

HPP theory of operation.

The HPP is a High Power Pulser. It is a linear current regulator with fast rise and fall time. The input voltage of the HPP must be higher than its output voltage. The ratio of V_{out}/V_{in} is roughly its efficiency.

The HPP is the most efficient pulser on the market given the rise time and fall time better than 15 μ s. In pulse mode, it communicates with the LDD power supply to adjust the LDD output voltage, which is the HPP input voltage to match the load voltage. The average input voltage for a given load varies due to pulse current, but pulse width is regulated such that at the end of the pulse, there will be about 1V across the "linear regulator". The average input voltage is higher than the load voltage because the voltage on the internal capacitors will have some droop during the pulse.

The HPP utilizes a proprietary scheme to have fast rise time even though the input voltage is a few volts higher than the output voltage, this gives the HPP the highest efficiency for a linear regulator, and the inductance of the output cable seems to have disappeared.

This feature also allows the voltage tracking when the laser diodes get hot and reduce their forward voltage drop, V_f .

The HPP communicates with the LDD to decrease the output voltage up to 25% of the programmed voltage in order to have good efficiency. The requirement is that the LDD output voltage must be programmed to be higher than the expected load voltage, but not too high that the HPP cannot pull it down to have 1V at the end of the pulse. The HPP has a pulse width limit (energy protection or poor load-match detector) that will limit pulse width to 10 μ s once the input voltage is 50% higher than the load voltage.

See section 11 Operation of the HPP for detailed operation setup.

For proper voltage programming, set and record the input voltage as follows: Program the output voltage to about 20% higher than the expected load voltage.

The voltage setting must be done with the Pulse signal set to OFF. When the pulse signal is set ON (Pulsing), the HPP will pull down the LDD output as it tries to regulate the LDD in normal operation.

How to set up the system with an oscilloscope:

The oscilloscope must be floating, on the safe side, REMOVE the Ground prong on the scope power cord.

Use a 4-channel scope if available. 2-channel is OK.

Reference all Ground leads to the Negative DC Input of the HPP. It is NOT the same as the Negative output of the power supply due to high current ground loop.

For the following scope trace, the channel descriptions are

Channel 1: Output Current. 1V = 100 Amp.

Channel 2: Pulse signal input, from output of the Isolator.

Channel 3: Negative output terminal of the HPP.

This is the voltage across the linear regulator.

Channel 4: Buss voltage at the Positive input of the HPP.

Math: Load voltage, Channel 4 – Channel 3.

Run pulses with lower than 50% max pulse current. The input voltage will be reduced automatically. Monitor the output current to make sure the pulse shape is correct. Reduce the input voltage further by reducing the V-program signal on the LDD until the output current fails to regulate at the end of the pulse. This is the minimum input voltage required for this particular load. Now stop the HPP pulsing and program the LDD output voltage about 20% higher than this minimum voltage. Make sure the HPP is OFF (disabled) at this time. The output pulse should be as shown in Figure 7 below.

If the voltage is so high that the HPP cannot pull it down to have 1 to 2V at the end of the pulse, the system will be inefficient which will result in overheating and shut down. On the oscilloscope, the buss oscillates, resulting in unstable output current.

If the input voltage is 50% higher than the load voltage, the HPP will operate in minimum pulse width (10 μ s) by the “poor load-match” detector.

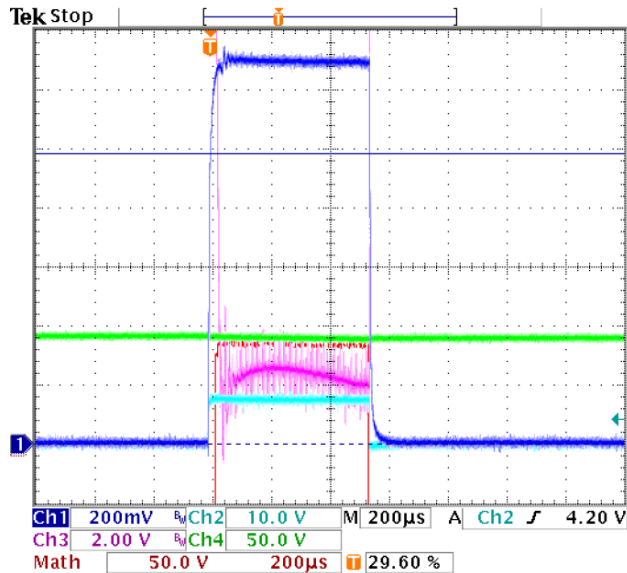

**Figure 7, Good setting with 2V across the regulator at the end of the pulse
 Channel 3, at ~130 Amp, 95V.**

The HPP has an optional programmable simmer up to 12Amp. The simmer current is ON when the pulse current is OFF and OFF when the pulse current is ON.

See section 11 Operation of the HPP for full details of operation setup.

CW/Pulse mode selection: (Optional)

To be used only to improve efficiency. Recommend NOT to be used in CW mode, as the control is complicated.

In some applications where the system can switch from pulse to CW, the signal CW/Pulse can be used.

When in Pulse mode, the HPP is working as a linear regulator and puts out the pulsed current requested at the I-program signal. This operation will require some voltage across the linear regulator and that translates into power loss.

When in CW mode, the transistors in the linear regulator are saturated and the only loss will be the Rds-on of the FET bank against the output current. The HPP is now acting as a wire with the impedance of the Rds-on and the current should be controlled by the LDD.

It is advisable that the HPP must be disabled, LDD output voltage should be programed to lower than the load voltage, and current should be programmed to minimum when switching from pulse to CW mode.

CAUTION: If the output voltage is higher than the load voltage, there will be current spikes to the load that may damage the load.

Another option is to run the HPP at 100% duty cycle. In this case, we can turn the HPP current program to 105% and control the output current by the LDD.

7.LDD with HP option

In a standard LDD, the output voltage is set to be 105% of, or about 10V above the required load voltage and it is just the compliant voltage, determined by the load.

The LDD-pp-xx-yy-HP is the Laser Diode Drive were -HP option designates the additional feature of programming and regulating the output voltage. The LDD-HP is normally set to be 5V to 10V higher than the load on the companion HPP.

Additionally, the LDD-HP has a pair of twisted wires to communicate with the HPP. This pair of wires is working in conjunction with the V-Program signal to determine the output voltage. This wire pair can only lower the LDD output voltage by 50%. At the end of the pulse, the HPP compares the cap bank voltage against the load voltage and tells the LDD to adjust the voltage so that it has about 1V to 2V difference. The communication is active only when the HPP is running (pulsing). If the HPP is in standby, the output voltage will rise to the level set by the V-Program signal.

When running with the HPP, set the LDD output current internally set about 5% more than the max average HPP current. For example, consider the HPP-2000-200-50-500. That is 2000 Watts, 200 Amp, 50V, 500 μ s max pulse width.

Calculation:

Pulse power: $200A * 50V = 10,000$ Watts.

Pulse energy: 500 μ s of 10000 Watts is 5 Joules.

Max frequency: $2000 \text{ Watts}/5 \text{ Joules} = 400$ Hz.

Duty Cycle: $500\mu\text{s}/400\text{Hz} = 20\%$.

Setting on LDD: $V_{\text{out}} \sim 55V$

$I_{\text{-out}} = 105\% * P/V_{\text{load}} = 1.05 * (2000/50) = 42$ Amp.

The LDD interface is listed below for reference.

LDD-6000-XX-YY -HP

Connector Type 15 pin D-sub Female

Pin #	Pin Name	Functional Voltage Level	Description
1	Enable (input. 10k impedance)	High = RUN = +5V to +15V Low = OFF = 0V	The Enable function turns the output section of the power supply ON and OFF. Enable signal must be inserted AFTER AC power has been applied as the power supply starts up Disabled disregarding the state of the Enable signal.
2	V-Program	0 – 10V = 0-Full Scale Only when the Pulse signal on the HPP is OFF or twisted pair to HPP disconnected.	Program Output Voltage. Open = Default = Full Scale.
3	Interlock	Open = OFF Connect to GND = RUN	The Interlock function can be connected to external interlock switches such as door or over-temp switches.
4	GND		
5	V-Monitor: (Output 100Ω impedance)	0 – 10V = 0 – Full Scale	Monitors output Voltage.
6	I-Mon (Output 100Ω impedance)	0 – 10V = 0 – Full Scale	Monitor Output Current
7	I-Program (Input 200k impedance)	0-10V = 0 – Ioutmax optional. Usually internally set for 105% of HPP max current.	The power supply output current is set by applying a 0-10V analog signal to Iprogram(+).
9	GND		
10, 11	5V @0.2A (output)		Auxiliary 5V power supply for user. Up to 0.2A output current available.
12	-15V @0.2A (output)		Auxiliary -15V power supply for user. Up to 0.2A output current available.
13, 14	15V @0.2A (output)		Auxiliary 15V power supply for user. Up to 0.2A output current available.
15	GND		

8.LDN with HP option

Another compatible power supply is the LDN series with the HP option. The LDN is available with the HP option. Since the LDN is only capable of 2000 Watts, the HPP can tolerate more overhead voltage. Please consult the factory for further information.

9.HPP-6000 Specifications

Model	Average Pout	Output Current	Input Voltage	Size (L x W x H)
-------	--------------	----------------	---------------	------------------

HPP-6000-XX-YY-ZZ	6000W	Up to 1000A Pulse 150A CW	15 – 160VDC	12” x 8.1” x 3.5
Where XX = I _{outmax} YY = V _{compliancemax} XX * YY * Duty Cycle cannot exceed 6000W				
Auxiliary Outputs: +15V @0.2A,				

Input

Voltage 15-160 VDC current source, voltage limited

Output

Power 6000 Watts average
Pulsed Current up to 1000 A peak
Continuous Current up to 150 A
Cable 1m (39.4 inch) long, included with unit

Interface

Connector 15 Pin “D” Sub Female
Pulse Current Program 0-10V for 0-Max Current
Current Monitor 0-10V for 0-Max Current
Simmer Current Program 0-10V for 0-Max Simmer Current
Aux. Output +15VDC @ 0.2A on interface

Performance

Max Rep Rate: 5 kHz
Rise/Fall Time: ~15 μs typical (10% to 90% Full Current)
Current Regulation: 0.5% of maximum output current
Current Ripple: <0.5% of maximum output current
Current Overshoot: <1% of maximum output current
Efficiency: >90% at full load

Environment

Operating Temp 0 to 40 °C
Storage -20 to 85 °C
Humidity 0 to 90% non-condensing
Cooling Forced air
Altitude and Pressure 2000 meters maximum, 80 to 103 kPa

Dimensions

Outline Please see Figure 14, HPP Mechanical Outline Drawing
13.8 inch length, 8.15 inch wide, 3.93 inch high
(does not include mounting flanges or electrical terminals)

10.HPP Interface

Connector Type 15 pin D-sub Female

Table 1, HPP Interface

Pin #	Pin Name	Functional Level	Description
1	Pulse Input (input, 10k impedance)	High = RUN = +5V to +15V Low = OFF = 0V	The Pulse function turns the pulse current On/OFF at high speed when the power supply is enabled. Current is delivered to load as programmed via Iprogram(+)
2, 3	GND		
4	Temp-Fault (Output, 10k impedance)	0V = Good 15V = Over Temp Fault	Stops power supply when internal heatsink(s) reaches 75 °C
5	Iout Monitor: (output)	0 – 10V = 0 – Full Scale	Monitors output current in real time.
6	Iprogram(+): (input, 20k impedance)	0 – 10V = 0 – Full Scale	The power supply output current is set by applying a 0-10V analog signal to Iprogram(+) . Iprogram must be higher than simmer program on pin 9.
7	Reserved (Output, 10k impedance)		DO NOT CONNECT
8	Voltage Adjust Return	Return Signal for Voltage Adjust loop to LDD power supply	DO NOT CONNECT
9	Simmer Program (input, 100k impedance) (Optional)	0 – 10V = 0 to 12Amp simmer current	Programmed DC simmer current will be present when in Pulse mode and when the power supply is Enabled. Max simmer power is limited to 20% of system average power.
10	CW/Pulse (Input, 10k impedance)	CW mode = +5 to +15V 0V = Pulse mode, default	Pulser becomes a virtual short in CW mode.
11	15V @0.2A (output)		Auxiliary 15V power supply for user. Up to 0.2A output current available.
12	Ready (output, 10k Impedance)	0V = Not Ready. 15V = Ready.	Power supply starts up = OFF. Insert Enable signal after power-up to initiate Ready signal.
13	Auto Voltage Adjust	Output to LDD-HP	Automatically adjusts the output voltage of the LDD power supply for optimal efficiency if load voltage varies. DO NOT CONNECT
14	Enable	RUN = +5V to 15V OFF = 0V, default	The Enable function turns the output section of the power supply ON and OFF. When the power supply is enabled, Pin 1 pulse control is operational and current is delivered to the load as programmed via Iprogram(+).
15	Interlock	Open = OFF GND = Operate	The Interlock function can be connected to external interlock switches such as a door. Ground to pin 2 or 3 to operate.

11. Operation of the HPP

Warning – Output Floating

Do not connect the HPP output or laser diode load to any ground, it must remain floating, or serious damage to the power supply and laser diode will occur!

The output of the HPP is floating and therefore, neither side of the laser diode is allowed to be connected to the same ground as signal ground (Program, Monitor).

Warning – Output Floating

Do not connect an oscilloscope or any instrumentation directly to the laser diode load! Only floating measurements can be used such as a differential voltage probe and Hall Effect current sensors.

Warning – Voltage Compliance Requirement

Each HPP is custom configured to deliver current pulses into a diode array requiring a predefined compliance voltage.

See the Serial Number label of the unit for the compliance voltage rating. The HPP takes DC input voltage and will not operate properly when the input is great than 10V higher than the load compliance voltage and will not start when the input is 20V lower than the rating on the S/N label or lower than 20V.

Consult factory more wider operating window.

1. Connect diode laser load to the HPP. A custom strip line or twisted cable is supplied to minimize inductance. Please note the cable is marked with (+) and (-) labels. Do not extend output cable or performance will be compromised.
Connect the HPP Isolator to the HPP Interface Connector. Make sure **Iprogram(+)**, pin 6, is set to 0.0V. **Note:** +15 volts, 200mA is required on pin 11 when the Opto Isolator Module (Part number 11001377) is used.
2. Connect HPP to the feeding DC power supply which is OFF.
3. Connect 24VDC to 24V connector on HPP.
4. Turn ON 24VDC supply.
5. Turn ON the feeding DC power supply. Increase DC output voltage and the HPP will start when it sees appropriate DC voltage. See Setting the Voltage Programming below for proper setup.
6. Set **Iprogram(+)**, Pin 6 of the interface connector, This signal is the 0-10V program which will program the output current level. Calibration is set so that 0-10V = 0 – $I_{out_{max}}$.
7. **Enable** the output by applying a TTL level high signal to pin 14 of the interface connector. The **Enable** control checks for faults and prepares the system for pulsing.
8. Pulse the unit via the **Pulsing Input** control, pin 1. Maximum pulse widths should not be greater than specified on the system label. The amplitude of the pulses will be determined

via the analog **Iprogram(+)** signal. Maximum average power delivered to the load should not exceed the rated power capability of the unit.

Measurement during setup with an oscilloscope:

The oscilloscope must be floating; either REMOVE the ground prong on the scope power cord or use a differential voltage probe.

Use a 4-channel scope if available. 2-channel is OK.

Reference all Ground leads to the Negative DC Input of the HPP. It is NOT the same as the Negative output of the power supply due to high current ground loop.

The following scope traces have the inputs set as follows:

- Channel 1: Output Current. 1V = 100 Amp.
- Channel 2: Pulse signal, from output of the Isolator.
- Channel 3: Negative output terminal of the HPP.
This is the voltage across the linear regulator.
- Channel 4: Buss voltage at the Positive input of the HPP.
- Math: Load voltage, Channel 4 – Channel 3.

When the HPP and LDD are correctly set up the output pulse should look like Figure 8 below.

Setting the Voltage Programming

At the beginning, ALWAYS set the LDD bus voltage LOWER than the expected load voltage. Monitor HPP output current and slowly increase LDD output voltage to have a perfect square wave on HPP current.

Measure and record LDD output voltage.

During production operation, set the LDD output voltage 7V - 10V higher than the recorded voltage. Set LDD voltage ONLY when the Pulse signal = OFF.

For proper voltage programming, set and record the input voltage as follows:

1. Program the output voltage to about 7-10V higher than the expected load voltage. The voltage setting must be done with the Pulse signal = OFF. When the pulse signal = ON (Pulsing), the HPP will try to pull down the LDD output as if it is trying to regulate the LDD in normal operation.
2. Run pulses with less than 50% max pulse current. The input voltage will be reduced automatically. Monitor the output current to make sure the pulse shape is correct.
3. Reduce the input voltage further by reducing the V-program signal on the LDD until the output current fails to regulate at the end of the pulse, see Figure 12 & 13. This is the minimum input voltage required for this particular load.
4. Set the HPP Pulse Input to off and program the LDD output voltage about 7-10V higher than the minimum voltage from step 3. Make sure the Pulse signal is OFF (disabled) at this time.

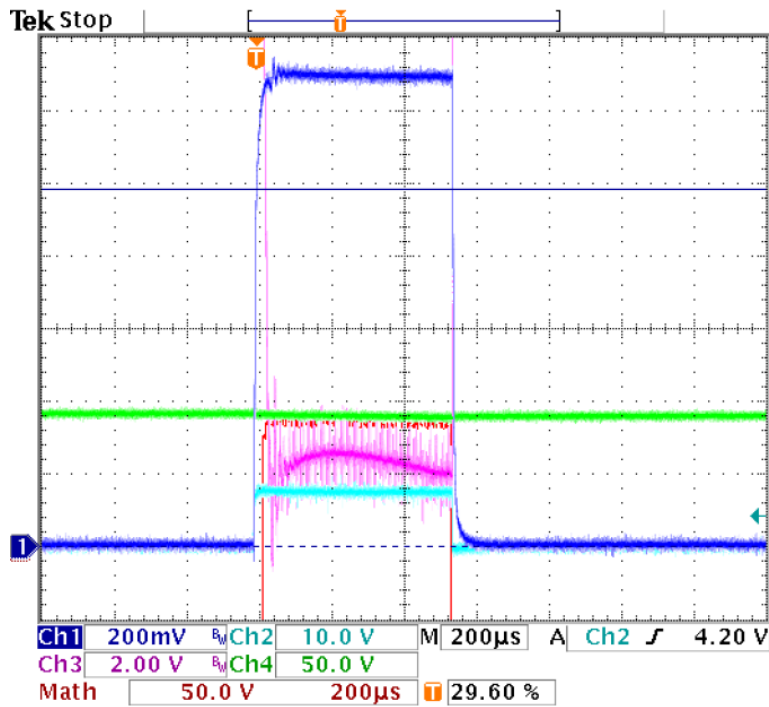

Figure 8, Good setting with 2V across the regulator at the end of the pulse Channel 3, at ~130 Amp, 95V.

A correct setup pulse train is shown below in Figure 9 for a 100A output pulse and 90V input to the HPP.

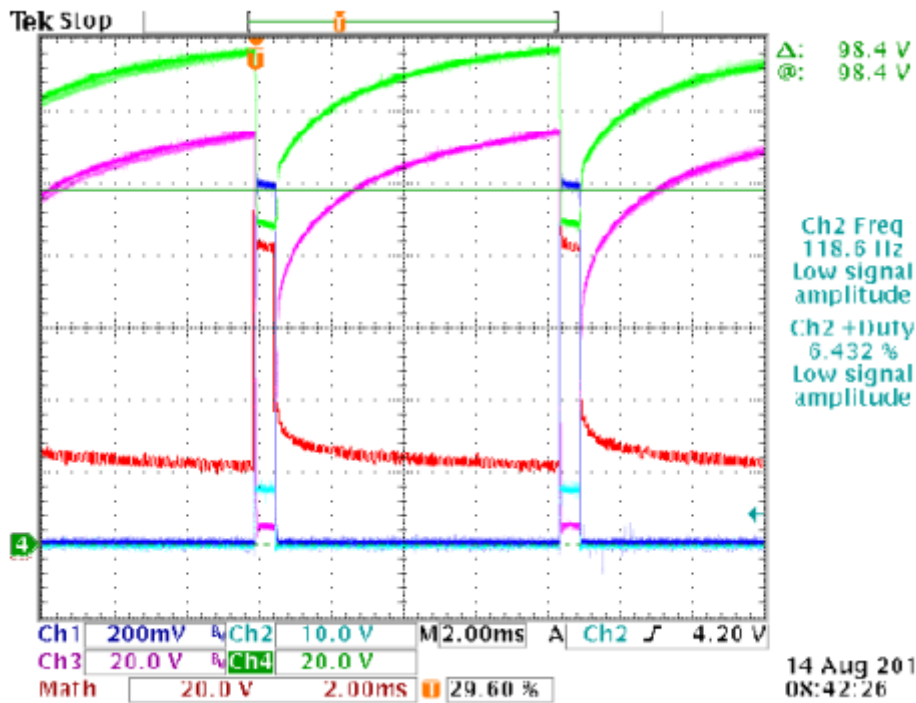
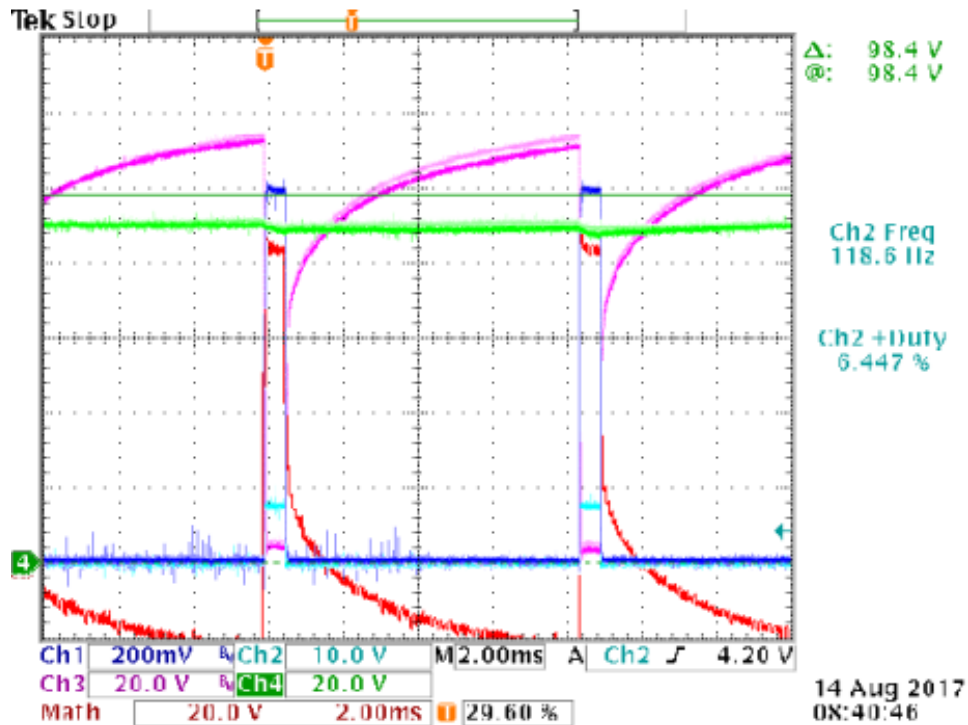

Figure 9, Good Pulse Train Stable Operation at 100A output, 90V input.

If the voltage is so high that the HPP cannot pull it down to have 1V -2V at the end of the pulse, the system will be inefficient which will result in overheating and fail. The buss oscillates, resulting in unstable output current. In Figure 10 & 11 the HPP negative output terminal, channel 3, is oscillating between 4.5 and 6 volts indicating that the input voltage is too high.



**Figure 10, Buss voltage set too high,
The HP cannot pull down the LDD output voltage, causes oscillation.**

If the input voltage is 50% higher than the load voltage, the HPP may operate in minimum pulse mode which limited by the “poor load-match” detector.

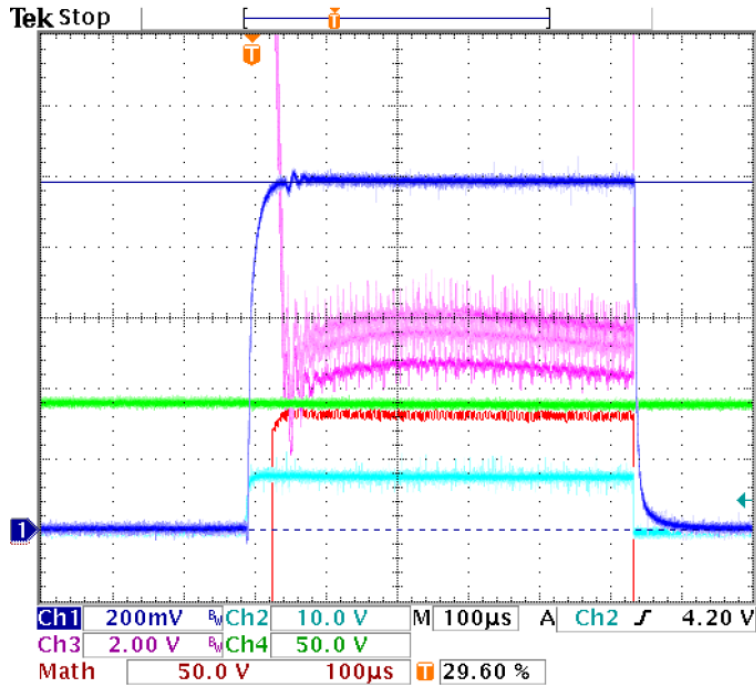

**Figure 11, Buss voltage set too high,
The HP cannot pull down the LDD output voltage, causes oscillation.**

If the buss voltage is a little too low then the output current starts to droop as shown in Figure 12 below. The HPP negative output on channel 3 indicates less than one volt so the linear regulator cannot regulate the output current.

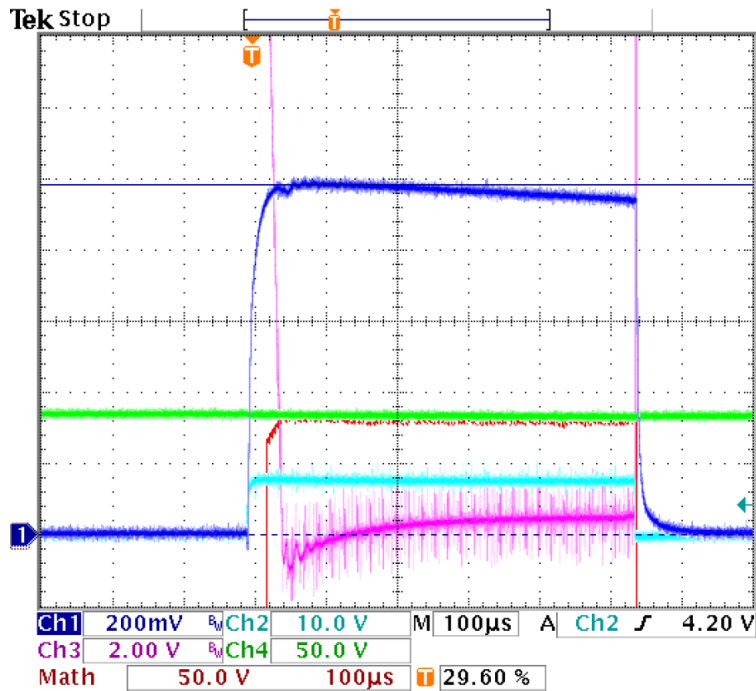

**Figure 12, Buss voltage set too low
output current starts to droop**

If the buss voltage is very low then the linear regulator cannot regulate at all current drops to the I-V curve of the load as shown in Figure 13 below.

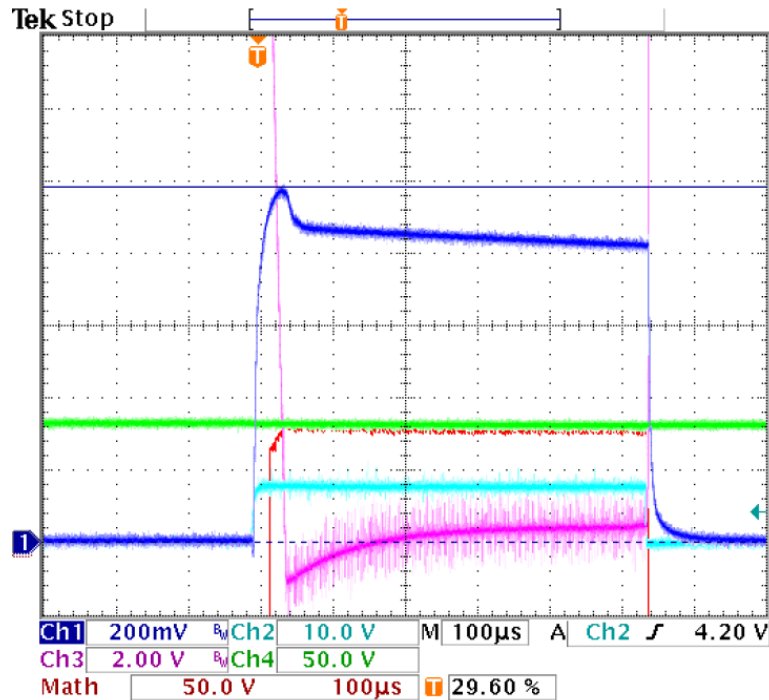

Figure 13, Buss voltage extremely low, output current overshoots and does not regulate.

Unit Faults

The unit is designed to monitor various faults such as:

- **Temp Fault: (Output, TTL, Pin 4)** When the temperature of the internal heat sink has exceeded a safe operating level, the system is shut off and this fault is transmitted. Fault output is TTL high. Fault can be cleared by setting the **Enable**, pin 14, to TTL low and then high.

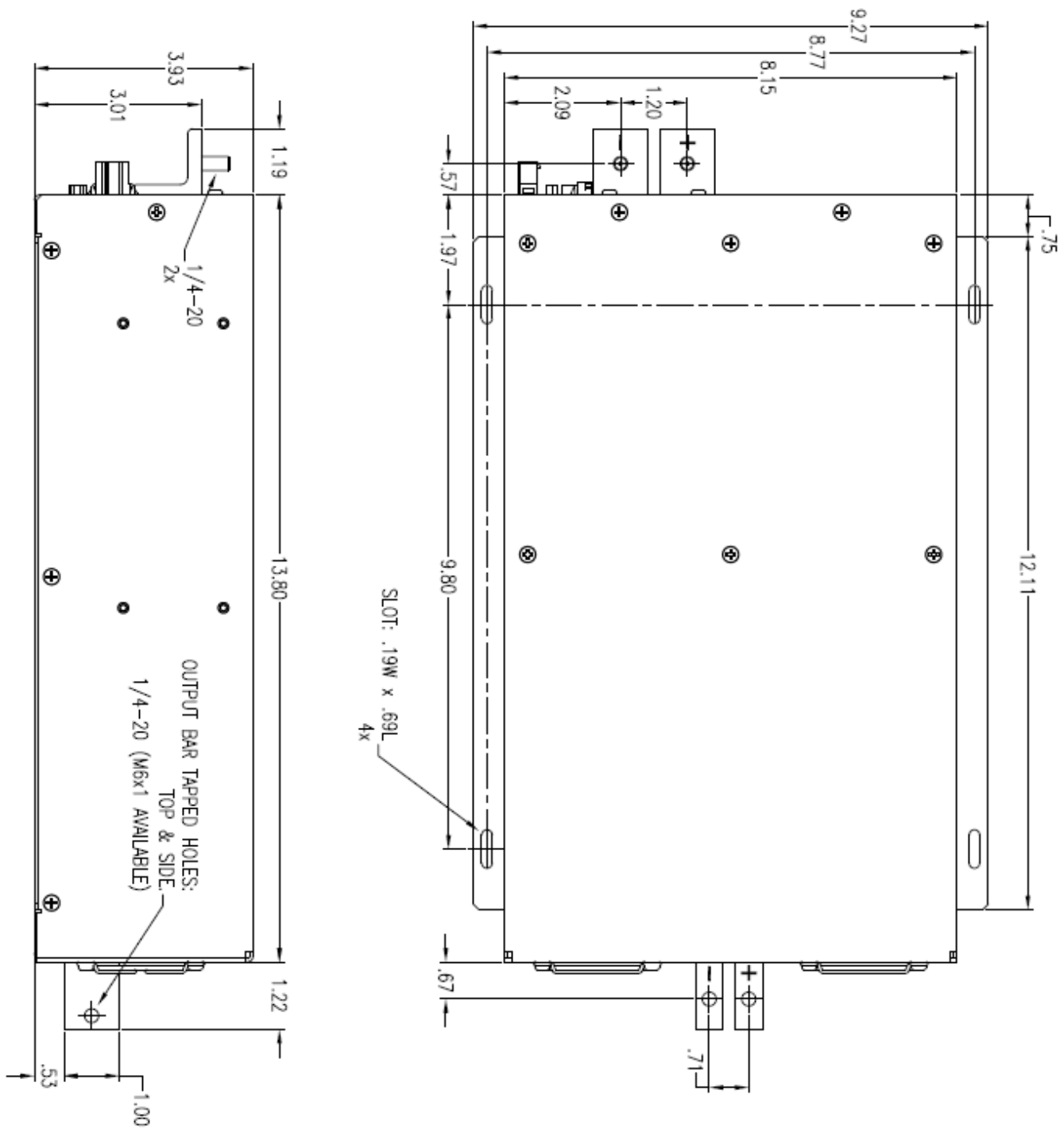
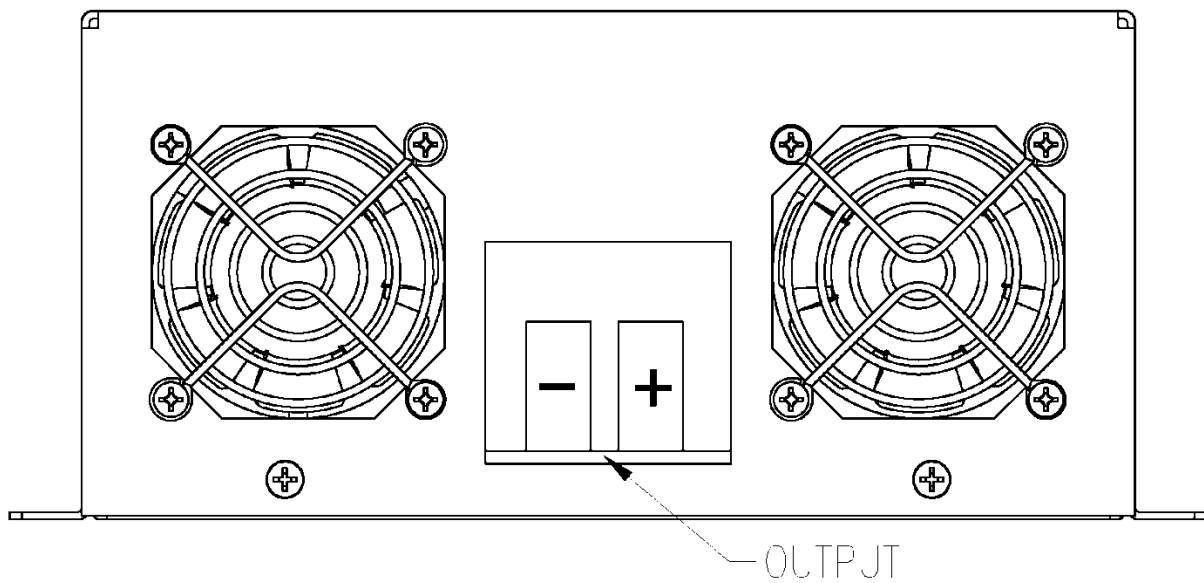
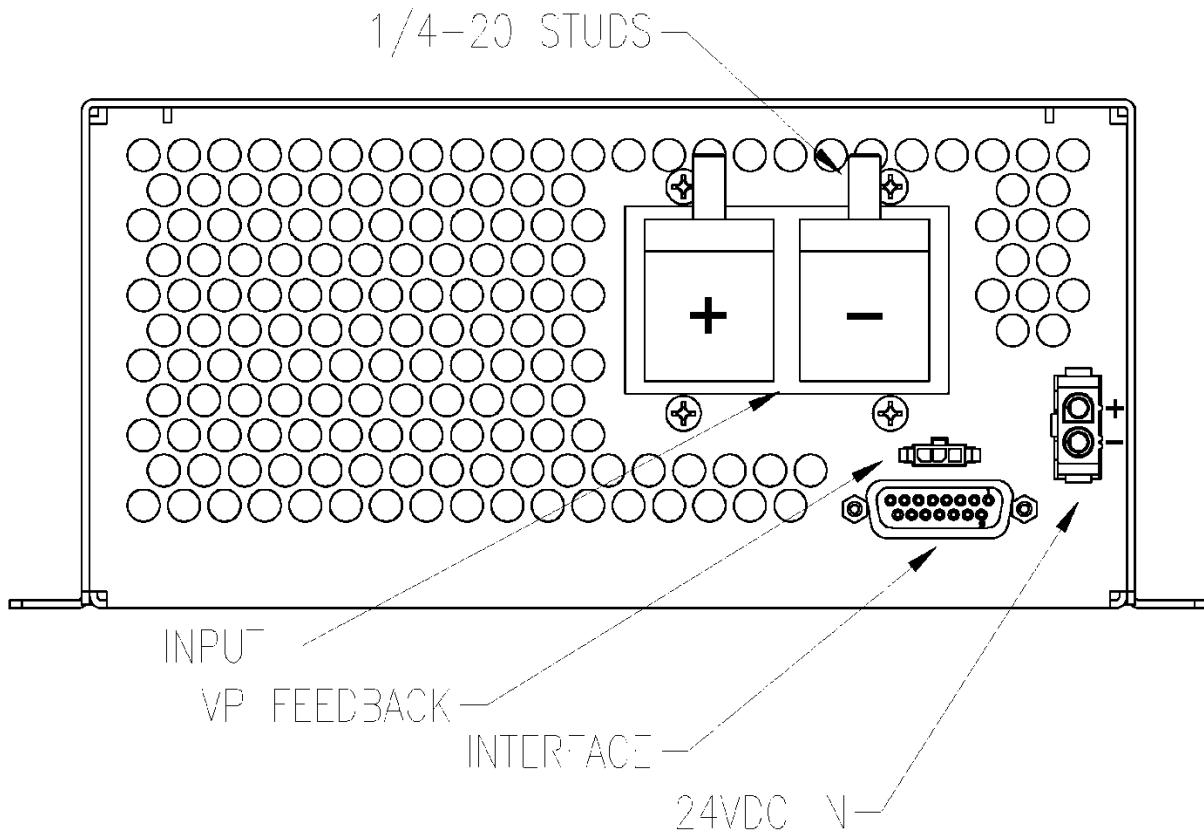

Figure 14, HPP Mechanical Outline Drawing



3

Figure 15, HPP Connections

12.Product Limited Warranty

Lumina Power, Inc., as Seller, warrants that each Product sold by it is free of defects in materials and workmanship. Duration of warranty is as follows:

- a. All Chassis enclosed products are covered for twenty four (24) months from date of shipment. Products included but are not limited to the following product families: CCPF, CCHP, LDY, LDYHC, LDQCW, XLB (excluding XLB-300), and MLB. Custom fully enclosed products may be covered for the same 24 months. Please consult factory for specific terms.
- b. All Open Frame products are covered for 12 months from date of shipment. Open frame power supplies are defined as any product that is not enclosed in a metal or plastic enclosure. Products included but are not limited to the following product families: LDPC, LDQPC, XLB-300 and any open frame custom products.
- c. All products returned for repair are covered for a period of 6 month or the balance of the original warranty, whichever is longer.

Warranty is not transferable to parties outside of original Buyer's corporate or educational organization. Seller will have sole discretion in making determination of validity of warranty if the Product is transferred to a different user group than the original Buyer.

Normal wear and tear and items expendable in normal use are not covered by this warranty. All warranty repair or replacement of parts shall be limited to Product malfunctions, which, in the sole opinion of Seller, are due or traceable to defects in original materials or workmanship. Such determination will be made when the Product is returned to the Seller's factory, transportation prepaid by the Buyer, within the warranty period.

All obligations under this warranty shall cease immediately in the event of abuse, accident, alteration, misuse, or neglect of the Product. Use and service of the Product in a manner not in accordance with the Owner's Manual (if furnished) will likewise cause all obligations under this warranty to cease. Repaired or replacement parts are warranted only for the remaining unexpired portion of the original warranty period for the Product. After expiration of the applicable warranty period, Buyer shall be charged at the then current prices for parts, labor and transportation.

Seller has no responsibility under this warranty for the cost of any work (material, labor, and/or other expenses) performed by or incurred by Buyer or any third party for modification or repair of the Product unless specifically authorized in advance in writing by Seller.

Reasonable care must be used to avoid hazards. Seller expressly disclaims responsibility for loss or damage caused by use of its Products other than in accordance with proper operation procedures. Other than those expressly stated herein, there are no other warranties of any kind, expressed or implied, and specifically included but not by way of limitation are the implied warranties of fitness or merchantability for a particular purpose.

It is understood and agreed the seller's liability whether in contract, in tort, under any warranty, in negligence or otherwise shall not exceed the return of the amount of the purchase price paid by the purchaser and under no circumstance shall seller be liable for special, indirect, incidental or consequential damages. The price stated for the product is a consideration in limiting seller's liability. No action, regardless of form, arising out of the transactions of this agreement may be brought by purchaser more than one year after the cause of action has accrued.

Seller's maximum liability shall not exceed and buyer's remedy is limited to either (i) repair or replacement of the defective part of product, or at seller's option (ii) return of the product and refund of the purchase price, and such remedy shall be the buyer's entire and exclusive remedy.

13.Service

This unit contains no user serviceable parts. Service and repair should be performed only by qualified personnel from Lumina Power, Inc. For more information contact

Lumina Power, Inc.
26 Ward Hill Ave.,
Bradford, MA 01835
Ph: 978-241-8260
Fx: 978-241-8262

Email: sales@luminapower.com Web site: www.luminapower.com

Rev	ECO	Description	Doc Ctrl	Date	App
1	7670	Initial Release	MJ	6/21/2017	EK
2	7670	Operation setup update	MJ	9/15/2017	EK
3	7670	Update outline drawing (Fig 14 & 15), pg17	MJ	10/23/17.	EK
4	7982	Operation setup update	MJ	1/27/23	SY