

MLB-5000 Xenon Arc Lamp Driver

5000 Watts with Igniter

Features:

- **5000 watts output**
- **Low ripple current <0.5%**
- **Reliable short-pulse igniter**
- **Power Factor >.98**
- **Analog interface**
- **CE certified: IEC 60601-1**
- **Low cost, compact size**

The MLB-5000 is a high-performance current source designed to operate and control Mercury short-arc lamps. The design incorporates a constant power topology to precisely control the wide swings in lamp impedance as the lamp transitions from a cold start to full temperature operation. To properly start the lamp, the remote igniter delivers a fast rise time, short pulse for reliable ignition and reduced lamp electrode wear.

The MLB-5000 features a user-friendly analog interface that allows for easy programming and monitoring of output settings, as well as advanced safety features such as over-voltage, over-current, and over-temperature protection.

With a compact design and high efficiency, the MLB series of Mercury short-arc lamp drivers are reliable and cost-effective solutions for a wide range of applications requiring high intensity lighting.

Part Number Configurator

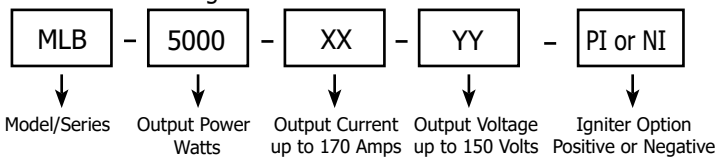

To complete the model description part number, please provide your required Max. Current for XX value and your required Max Voltage for the YY value and provide your required igniter polarity for either Positive or Negative.



Applications:

- **Semiconductor Processing**
- **UV Sterilization**
- **UV Spectroscopy**
- **UV Curing**
- **Industrial Processing**
- **Medical Applications**



Remote Short-Pulse Igniter



Specifications

Input	
Voltage (Factory Set)	200-240VAC $\pm 10\%$, 50/60 Hz, 3 \emptyset or 380-440VAC, $\pm 10\%$, 50/60 Hz, 3 \emptyset
Power Factor	.9@200Volts, .75@440Volts
Efficiency	>90%
Leakage Current	1mA
Output	
Power	5000 watts
Current (Max.)	170 Amps
Voltage (Max.)	150 Volts
Performance	
Line Regulation	<.2% of maximum output current
Current Regulation	<.5% of maximum output current
Current Ripple	<.5% of maximum output current
Power Limit	Limited to maximum power with fold back circuit
Certification	CE Certified; UL 61010-1 Issue:2012/05/11; Measurement, control, and lab use

Ignition/Boost	
Ignition Voltage	Up to $\sim 45\text{kV}$ ($\sim 1\mu\text{Sec}$, rise time)
Ignition Energy	65mj.
Ignition Polarity	Positive or Negative (factory set)
Boost Voltage	Up to 275V
Boost Energy	500 mj.
Environment	
Operating Temp.	0 to 40°C
Storage Temp.	-25 to 85°C
Humidity	0 to 95% RH non-condensing
Cooling	Forced Air
Dimensions	
Power Supply	L17.3" x W16.57" x H4.25" (439.4 x 420.9 x 108mm)
Igniter	L7.0" x W4.625" x H2.5" (177 x 116 x 63mm)

Maximum output voltage is preset. Actual output voltage tracks the impedance of the lamp. Units can be paralleled for higher power applications.

Interface (15 pin D-Sub Female)

Pin#	Pin Name	Functional Voltage Level	Description
1	Lamp On/Off (input)	High = RUN = +5V to +15V Low = OFF = 0V	The Lamp On/Off function is the control function which turns the lamp on and off. When the lamp is turned on, a trigger and boost sequence will ignite the lamp and deliver power.
2	Current Limit	Analog Level, Default=10V	The Current Limit Pin is used to limit the output current of the supply. The pin can be pulled lower through the use of an external resistor to Gnd to limit the output current of the supply. The default setting is set to 105% of Ioutmax.
3	Interlock (Input)	Open = OFF, Connect to GND = RUN	The Interlock function can be connected to external interlock switches such as door or overtemp switches.
4,9,15	GND		Interface Return
5	Vout Monitor (output)	0-10V = 0-Vout max.	The output voltage of the supply can be monitored by Vout Monitor.
6	Iout Monitor (output)	0-10V = 0-Iout max.	The output current of the supply can be monitored by Iout Monitor.
7	Pprogram (input)	0-10V = 20%-Pout max.	Output power is set by applying a 0-10V signal to Pprogram.
8	Lamp Status	High = lamp off = 15V Low = lamp on = 0V	The status of the lamp can be monitored using this pin
12	-15V(output)		Auxiliary 200mA.
13,14	+15V (output)		Auxiliary 200mA.

Outline Drawings

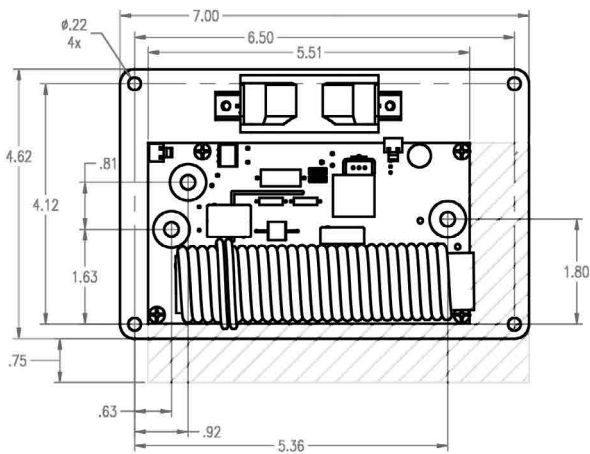

Igniter

