



**26 Ward Hill Ave., Bradford, MA 01835
Phone: 978-241-8260 Fax: 978-241-8262**

**USER MANUAL
CCPF-3500-XX
CCPF-4000-XX
3.5 to 4.0 kJ/s Capacitor Charging
Power Supply Series**



Table of Contents

1. Description of CCPF-3500-XX Power Supply	3
2. Explanation of Symbols.....	4
3. CCPF-3500 Specifications	5
4. CCPF-3500 Interface	6
5. Typical Applications.....	9
5.1 Using a CCPF with a pulse forming network (PFN)	9
5.2 Using a CCPF with a partial discharge network (Reservoir Charging)	10
5.3 Using a CCPF with multiple PFNs or capacitors	11
6. Warnings	12
7. Installation	13
8. Product Limited Warranty	14
9. Service	15

Tables and Figures

Table 1, CCPF Interface	6
Table 2, CCPF Connections	13
Figure 1, CCPF-3500 Block Diagram	3
Figure 2, CCPF-3500 Interface Schematic	7
Figure 3, CCPF-3500 Mechanical Outline Drawing	8

1. Description of CCPF-3500-XX Power Supply

The CCPF-3500/4000-XX capacitor charging power supplies are designed for OEM laser manufacturers. The CCPF-3500 power supply provides up to 3500 J/s average charging power for full discharge PFN applications, while the CCPF-4000 power supply provides up to 4000 J/s charging power for reservoir capacitor banks. The main power output provides a constant current to charge up a capacitor to the programmed value.

The CCPF-3500/4000-XX can be configured for maximum output voltages up to 4000V where the XX indicates the maximum output voltage. As an example, a CCPF-3500 configured for 1000V maximum output voltage is designated as a CCPF-3500-1P, where P indicates a positive output which is the standard polarity. An optional +24VDC output is available for auxiliary power.

The CCPF takes AC input from 200 – 240VAC, 50/60 Hz and rectifies it by the input rectifier bridge. The rectified voltage is boosted to non-isolated 400 VDC by the Power Factor Correction (PFC) circuit. The purpose of the PFC is to force the input current to be in phase with the input voltage, close to unity power factor; such that from 20% to 100% load the power factor is better than 98%. The PFC also produces the auxiliary power for the fans and control circuits. The 400 VDC power is the source for the inverter to generate the high output voltage for the capacitor load.

CCPF-3500-XX Block Diagram

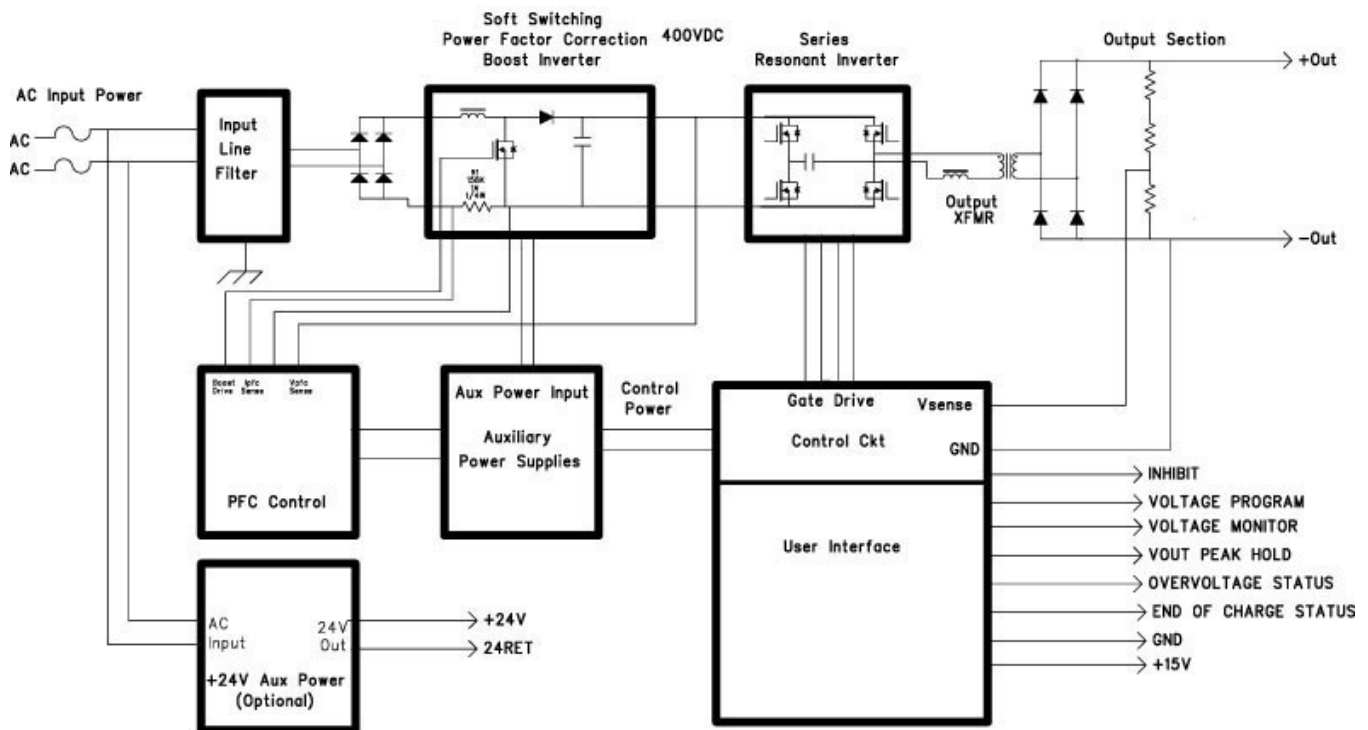

Figure 1, CCPF-3500 Block Diagram

2.Explanation of Symbols



Hazard: This equipment produces high voltages which can be fatal. Only service personnel of Lumina Power, Inc. are qualified to service this equipment.



High Voltage Present.This power supply produces lethal high voltages. Only service personnel of Lumina Power, Inc., are qualified to service this equipment. Only qualified service personnel are permitted to install this power supply.



Chassis Ground: This symbol where the protective earth ground connection is located.

3. CCPF-3500/4000-XX Specifications

XX indicates output voltage with P for positive and N for negative.

Input

Voltage	200 - 240 VAC, single phase
Current	22 A maximum at 200 VAC and 18.4A maximum at 240 VAC
Frequency	47 - 64Hz

Output

Power:	3500 J/s average charge rate for full discharge PFN 4000 J/s maximum charge rate for reservoir charging See section 5 Typical Applications below
Output Voltage	Fixed voltage between the ranges of 400VDC – 4.0kVDC (factory configured, contact factory for voltages > 4kVDC)
Polarity	Positive or Negative (factory configured)
Efficiency	>80% at full output
Regulation:	0.5% @100Hz
Aux. Output	+24VDC @ 3A (optional feature)

Interface

Connector	15 Pin “D” Sub Female
Voltage Program	0-10V for 0-Max Voltage
Voltage Monitor	0-10V for 0-Max Voltage
Inhibit/Reset	Input, low level (high level optional, contact factory)
End of Charge	Output indication
Overvoltage	Output indication
Overtemp	Output indication
Overload	Output indication
+15V Aux Power	

Environment

Operating Temp	0 to 40 °C
Storage	-20 to 85 °C
Humidity	0 to 90% non-condensing
Cooling	Forced air
Altitude and Pressure	2000 meters maximum, 80 to 103 kPa

Dimensions

Outline	Please see Figure 3, CCPF-3500 Mechanical Outline Drawing 14.2 inch length, 5.5 inch wide, 6.0 inch high (does not include mounting flanges or electrical terminals)
---------	--

4.CCPF-3500 Interface

Connector Type 15 pin D-sub Female
Refer to Figure 2, CCPF-3500 Interface Schematic

Table 1, CCPF Interface

Pin #	Pin Name	Functional Level	Description
1	Inhibit/Fault Reset (input)	Low = RUN, <0.3V High = OFF, +5V to +15V	This pin is the basic ON/OFF control pin for the power supply. Grounding pin 1 enables power supply operation if all faults are clear. Applying +10 to 15V to pin 1 prevents the inverter from operating. Optional High Enable available, contact factory, see note 2.
3	Over-Temp Fault (output) (optional, see note 2)	High = safe operation, +15V Low = Hot warning, <0.5V	Indicates an internal high temperature condition. When an over temperature fault occurs, the signal is pulled either to GND or 15V/5V based on specific customers' requirement. Please refer to the test data sheet for a specific power supply to see how that unit is configured. A N/O (a N/C switch is available) thermal switch closes during an over temperature condition. Under normal temperature conditions, the over temperature output is pulled to 15V via a 4.99k resistor. For a 5V interface, a 2.49k resistor is in parallel with the thermal switch. The thermal switch will reset itself when the temperature has been reduced by approximately 20°C.
4, 10, 12	No connect		Optional, may be used for customer specified functionality, see Note 2.
5	Voltage Program (input)	0 - 10V = 0 - Vout _{max}	Output is programmed externally with a 0 to +10V signal for 0 to Vout _{max} . See note 1. Note: Accuracy and linearity will be compromised when operating below 20% of the max value.
6	OVERVOLTAGE / OVERLOAD / NO LOAD STATUS INDICATOR (output)	High = OK, +15V Low= Overload, <0.5V	When the output is open or shorted circuited, or if the capacitor can't be fully charged to the programmed level in a given time, the Over-Load Fault will latch Low and the power supply will shut down to protect itself. Typically, it is 15V at an open collector with a 4.99k pull up during normal operation. To Clear the Fault: Correct the problem at the load and toggle the Inhibit signal or recycle the AC input.
7	Vout Peak Hold (output)	0 - 10V = 0 - Vout _{max}	Peak detect circuit of the output voltage monitor. The time constant is approximately 5 seconds. See note 1.
8	Vout Monitor (output)	0 - 10V = 0 - Vout _{max}	Monitors output voltage. See note 1.
9, 11	+15V @0.1A (output)	+15V ± 10%	+15VDC for customer interface, maximum output current is 100mA.
13	End of Charge Status Indicator (output)	High = Charging, +15V Low= Load charged to Voltage Program, <0.5V	When the load capacitor is fully charged to the programmed level, the EOC signal will go Low thru an NPN transistor. The signal is Normally High via a 4.99k pulled up to 15V. The EOC signal will toggle when the power supply is refreshing the load cap. Latched EOC is optional: The EOC signal will latch Low when the capacitor is fully charged and stays Low until the cap is discharged and the Inhibit signal is asserted.
14, 15	Ground (output)		Ground return for control interface signals.

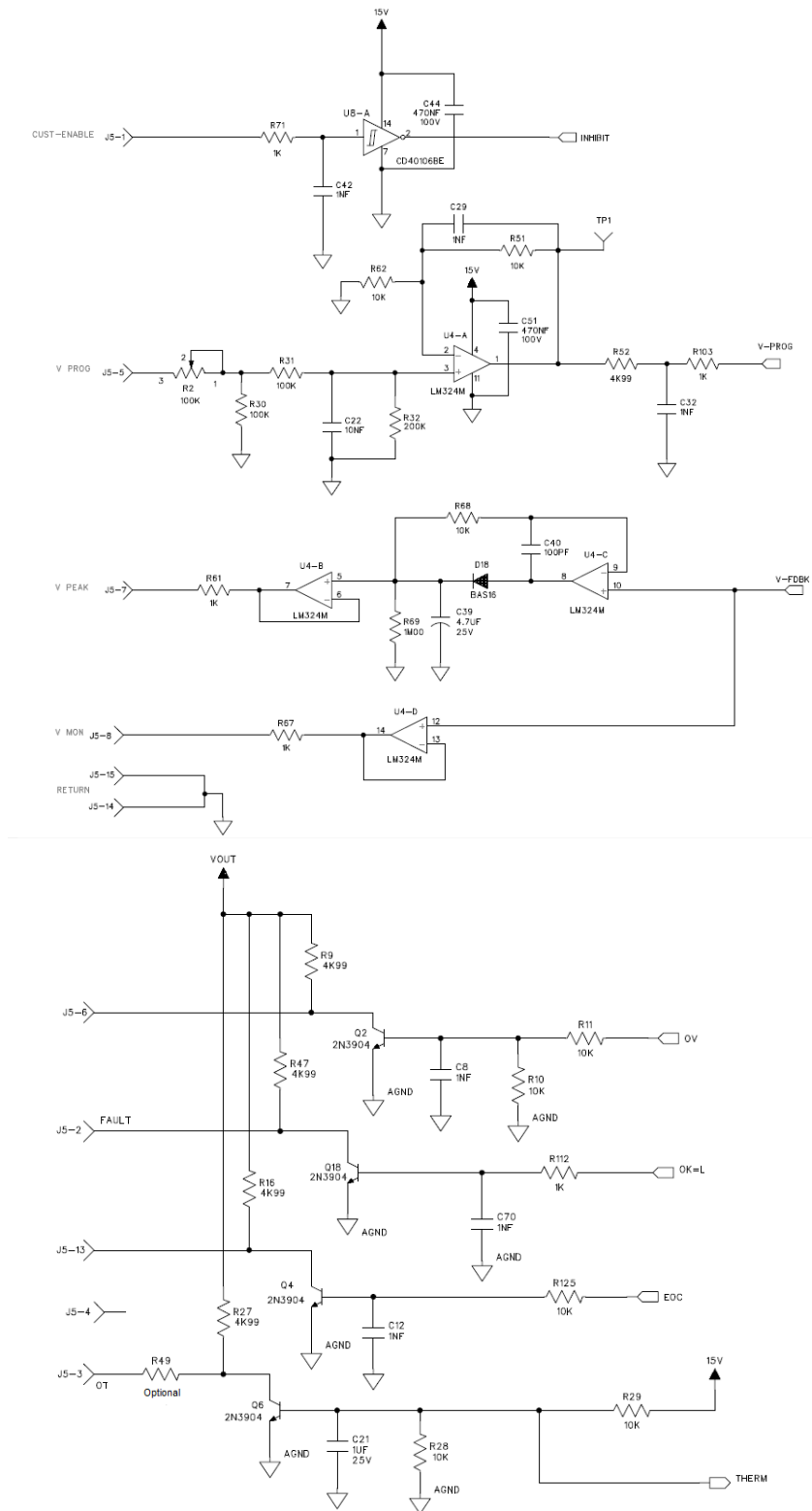

Figure 2, CCPF-3500 Interface Schematic

Notes:

1. Analog voltage range of 0-5V available per customer request.
2. Other interface configurations are available to conform to older capacitor charger models or customer requests, contact Lumina Power for any interface changes.

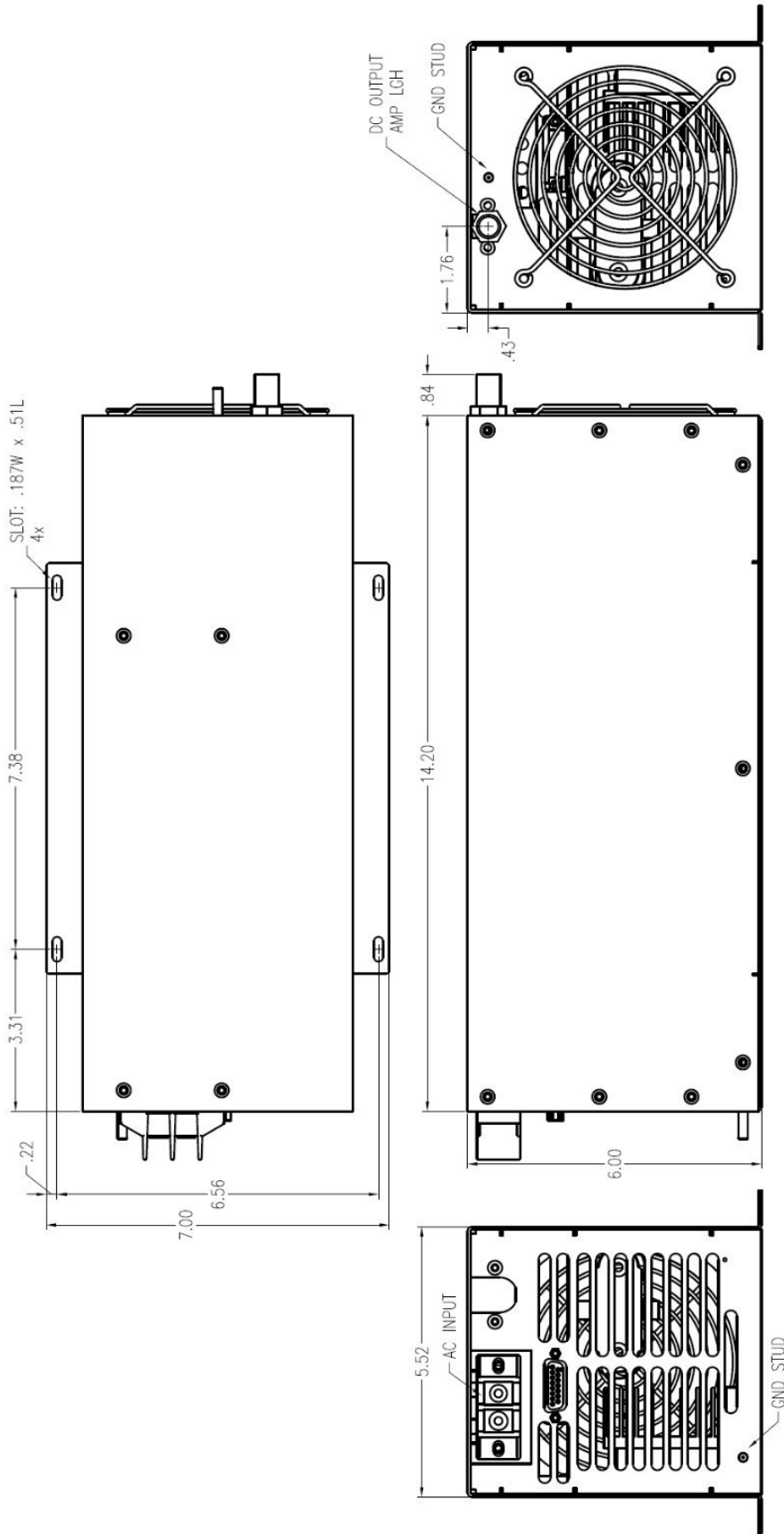
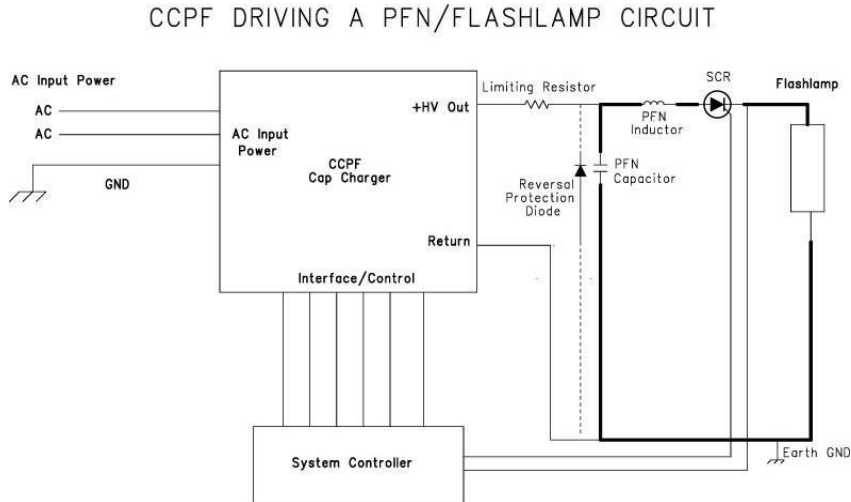

Figure 3, CCPF-3500 Mechanical Outline Drawing

5. Typical Applications

5.1 Using a CCPF with a pulse forming network (PFN)



The above block diagram shows a typical connection between a CCPF capacitor charging power supply and a well matched pulse forming network. In a typical operation, when the CCPF is ENABLED via Pin 1, the INHIBIT function, the CCPF will charge up the PFN capacitor to the programmed value and then transmit an END OF CHARGE signal to the user. Before discharging the load capacitor into the PFN, the CCPF should be disabled via the INHIBIT function. Once the PFN is completely discharged and the SCR has completely turned off, the charging function can be ENABLED via the INHIBIT function and the CCPF will charge the capacitor again to the programmed value. PFN designers may choose to include a limiting resistor and a reversal protection diode to protect the power supply if there is any possibility of an arc in the PFN circuitry.

5.2 Using a CCPF with a partial discharge network (Reservoir Charging)

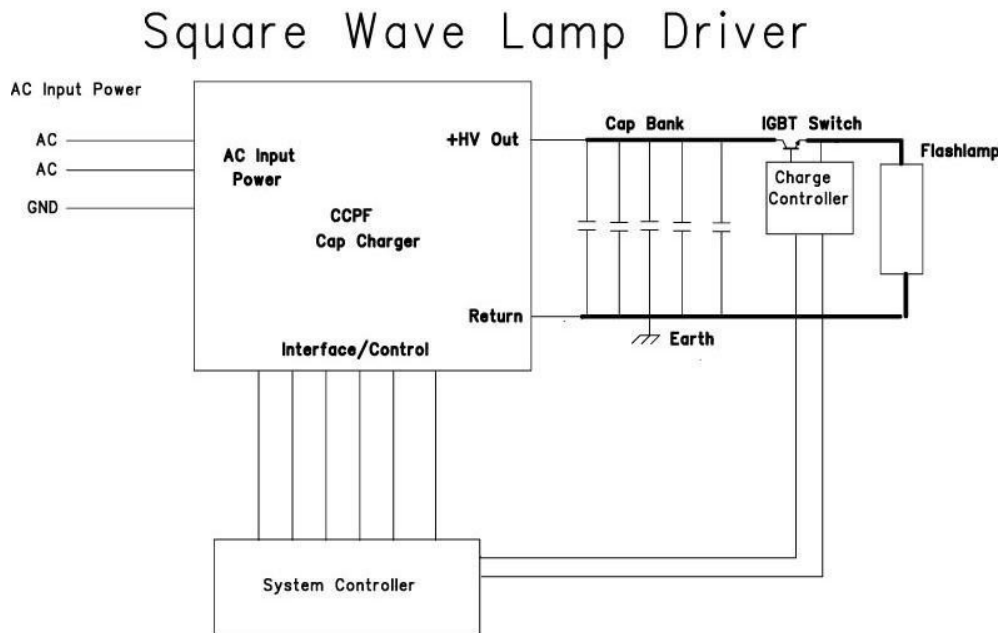

In this application, the power supply is ENABLED via the INHIBIT function and charges up the capacitor bank to the programmed voltage. The IGBT will deliver short, high current pulses to the flashlamp. The power supply does not need to be inhibited during this process and continuously maintains the capacitor bank charged.

5.3 Using a CCPF with multiple PFNs or capacitors

In applications where the power supply has to charge 2 or more separate capacitors which are discharged at different times, diodes must be used in series with the output to prevent one cap from discharge into the other. Also, a resistor must be in parallel with each diode to help the power supply to “see” the cap voltage which is now blocked by the diodes. Failure to add the parallel resistors will result in over charging the cap as the power supply does not see the real voltage on the caps.

The diodes must have voltage rated at least 300V higher than the max voltage and 2 times the current.

The resistor values are calculated as follows:

$$R \text{ (in Ohm)} \geq 100 * V_{out}.$$

$$P \text{ (in Watts)} \geq V^2 / R.$$

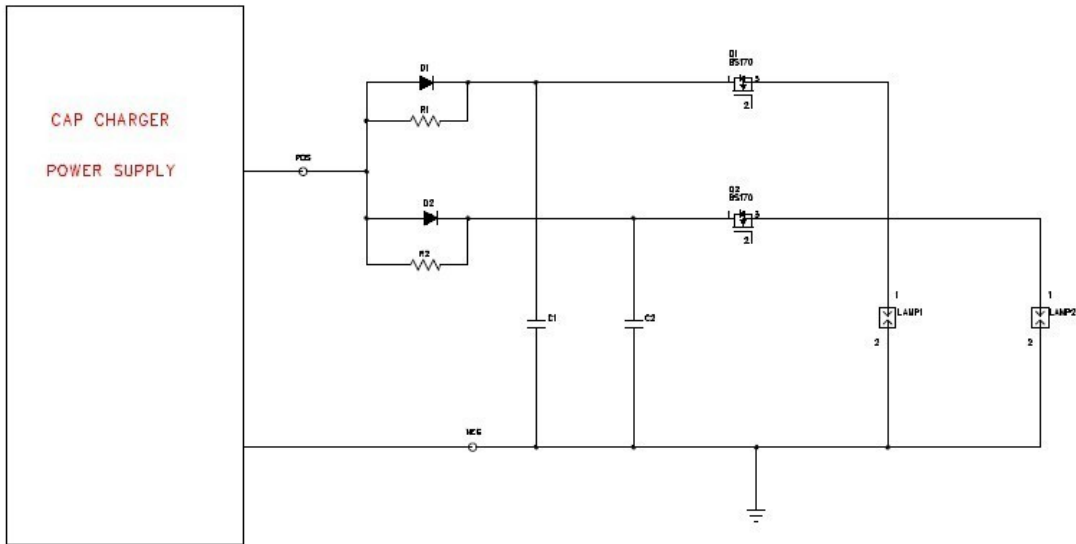

6. Warnings



High Voltage Present

This power supply produces lethal high voltages. Only service personnel of Lumina Power, Inc., are qualified to service this equipment. Only qualified service personnel are permitted to install this power supply.



Warning:

This equipment produces high voltages which can be fatal. Only service personnel of Lumina Power, Inc. are qualified to service this equipment.



Warning:

Equipment is not suitable for use in presence of a flammable anesthetic mixture with air or with oxygen or nitrous oxide.



Warning:

These power supplies are not provided with any isolation devices and shall only be used inside other equipment that has means to isolate its circuits electrically from the supply mains on all poles simultaneously.



Warning:

To avoid risk of electric shock, this equipment must only be connected to a supply mains with protective earth

WARNING : Only Lumina Power, Inc. qualified service personnel are allowed to remove the covers and service this equipment.

WARNING : **NEVER OPERATE THE POWER SUPPLY:**

1. Without providing adequate protection of personnel from high voltage.
2. Without proper ground connections.
3. Without covers and panels properly installed.
4. With customer interlocks defeated.
5. Without a suitable load for the application and properly rated for the required power dissipation.

7. Installation

These power supplies are designed for and intended only for installation into OEM pulse forming systems.

- Only qualified technicians or qualified assemblers may install these power supplies.
- Only qualified Lumina Power personnel may service these power supplies.
- There are no user serviceable parts in this equipment.
- **Required wire and connectors:** Refer to Figure 3, CCPF-3500 Mechanical Outline Drawing for the locations of connections. Table 2, CCPF Connections below shows required cables and connectors:

Table 2, CCPF Connections

Connection	Description	Required Wire and Connectors
AC Input Power	2 Position terminal strip #10-32 stud for ground	At least 12AWG wire
Interface	15 pin "D" female	15 pin "D" male
HV Output	TE/AMP LGH receptacle *See note below	LGH plug with coax cable rated for at least 150% of maximum output voltage of unit
24V Aux Output (optional)	2 Pin Tyco Mate-N-Lok Connector.	Tyco 35077-1 2 Pos Plug (Digikey P/N A14279-ND) Tyco 350550-1 Contacts (Digikey P/N A1441-ND)

* Note: other connectors or flying lead configuration also available, contact Lumina Power for any interface changes.

- **Ventilation:** This unit is forced air cooled via internal DC fans. A clearance of 2" should be maintained at either side of the power supply the fan end of the power supply as well as the grill side of the power supply. Hot air exits the grill side and should be ducted out of the system. Do not let the hot air exhaust recirculate to the power supply air inlet. Fully sealed systems should implement a heat exchanger system to maintain the environmental conditions list in section 3 CCPF-3500/4000-XX Specifications on page 5.

IMPORTANT APPLICATION NOTE REGARDING AC INPUT POWER

AC Input wires should be at least #12 AWG,
rated for at least 600V and 105 Degree C.

8. Product Limited Warranty

Lumina Power, Inc., as Seller, warrants that each Product sold by it is free of defects in materials and workmanship. Duration of warranty is as follows:

- a. All Chassis enclosed products are covered for twenty four (24) months from date of shipment. Products included but are not limited to the following product families: CCPF, CCHP, LDY, LDYHC, LDQCW, XLB (excluding XLB-300), and MLB. Custom fully enclosed products may be covered for the same 24 months. Please consult factory for specific terms.
- b. All Open Frame products are covered for 12 months from date of shipment. Open frame power supplies are defined as any product that is not enclosed in a metal or plastic enclosure. Products included but are not limited to the following product families: LDPC, LDQPC, XLB-300 and any open frame custom products.
- c. All products returned for repair are covered for a period of 6 month or the balance of the original warranty, whichever is longer.

Warranty is not transferable to parties outside of original Buyer's corporate or educational organization. Seller will have sole discretion in making determination of validity of warranty if the Product is transferred to a different user group than the original Buyer.

Normal wear and tear and items expendable in normal use are not covered by this warranty. All warranty repair or replacement of parts shall be limited to Product malfunctions, which, in the sole opinion of Seller, are due or traceable to defects in original materials or workmanship. Such determination will be made when the Product is returned to the Seller's factory, transportation prepaid by the Buyer, within the warranty period.

All obligations under this warranty shall cease immediately in the event of abuse, accident, alteration, misuse, or neglect of the Product. Use and service of the Product in a manner not in accordance with the Owner's Manual (if furnished) will likewise cause all obligations under this warranty to cease. Repaired or replacement parts are warranted only for the remaining unexpired portion of the original warranty period for the Product. After expiration of the applicable warranty period, Buyer shall be charged at the then current prices for parts, labor and transportation.

Seller has no responsibility under this warranty for the cost of any work (material, labor, and/or other expenses) performed by or incurred by Buyer or any third party for modification or repair of the Product unless specifically authorized in advance in writing by Seller.

Reasonable care must be used to avoid hazards. Seller expressly disclaims responsibility for loss or damage caused by use of its Products other than in accordance with proper operation procedures. Other than those expressly stated herein, there are no other warranties of any kind, expressed or implied, and specifically included but not by way of limitation are the implied warranties of fitness or merchantability for a particular purpose.

It is understood and agreed the seller's liability whether in contract, in tort, under any warranty, in negligence or otherwise shall not exceed the return of the amount of the purchase price paid by the purchaser and under no circumstance shall seller be liable for special, indirect, incidental or consequential damages. The price stated for the product is a consideration in limiting seller's liability. No action, regardless of form, arising out of the transactions of this agreement may be brought by purchaser more than one year after the cause of action has accrued.

Seller's maximum liability shall not exceed and buyer's remedy is limited to either (i) repair or replacement of the defective part of product, or at seller's option (ii) return of the product and refund of the purchase price, and such remedy shall be the buyer's entire and exclusive remedy.

9. Service

This unit contains no user serviceable parts. Service and repair should be performed only by qualified personnel from Lumina Power, Inc. For more information contact

**Lumina Power, Inc.
26 Ward Hill Ave.,
Bradford, MA 01835
Ph: 978-241-8260
Fx: 978-241-8262**

Email: sales@luminapower.com Web site: www.luminapower.com

Rev	ECO	Description	Doc Ctrl	Date	App
1	7612	Initial Release	MJ	08/17/2016	EK