



Operators Manual

LDQCW-250-XX-YY-ZZ
LDQCW-600-XX-YY-ZZ



XX= Ioutmax YY = Maximum Compliance Voltage
ZZ = Max Pulse Width in usec

Warning – Voltage Compliance Requirement

Each LDQCW is custom configured to deliver pulses of current into an array requiring a predefined compliance voltage. The LDQCW will not operate properly when connected to an array that requires more than +105% or less than 75% of the rated voltage of the unit. See the Serial Number label of the unit for the compliance voltage rating. When driving a load requiring more than 105% of the rated voltage of the unit, output current will not reach the programmed value. When driving a load requiring a voltage less than 75% of the specified output voltage, the unit may shut off to protect internal circuitry from over-temperature conditions (see Pin 7 of the Interface)

Warning – Output Floating

The output of the LDQCW is floating and therefore, neither side of the laser diode is allowed to be connected to the same ground as signal ground (Program, Monitor).

I. Overview of LDQCW System

Lumina Power's LDQCW power supplies are designed for pulsing diode lasers in Quasi-CW applications. Before operating this unit, it is important to understand the operation. A block diagram of the power supply is shown below.

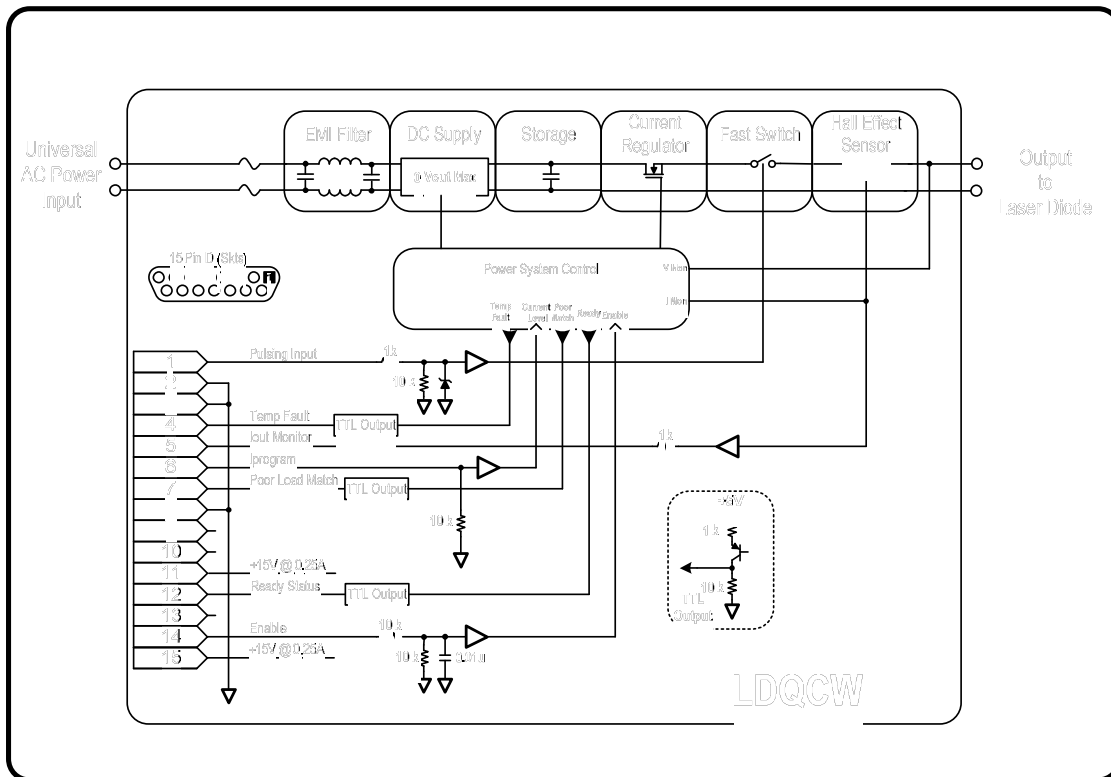

Figure 1 - LDQCW Block Diagram

Referring to Figure 2, it's easiest to think of the basic elements of the system as a high power linear regulator. The four main components are:

- A **DC input voltage** which is applied to the input of the regulator
- A **high power linear regulator** which is controlled by an error signal
- A **high current Hall-Effect current monitor**
- **Control system**

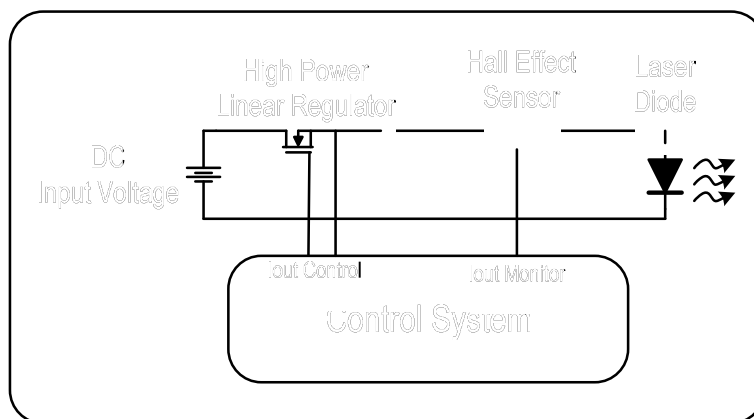

Figure 2 - Simplified LDQCW Block Diagram

The **DC input voltage** is, in fact, a sophisticated high frequency switchmode power supply which includes power factor correction, a soft switching inverter, an input line filter and various protection circuits.

The **high power linear** regulator is typically a bank of high power MOSFETS mounted on an appropriate heat sink with over-temp protection.

The **high current Hall Effect current monitor** provides a fast, low loss method to measure high current pulses.

The **control system** provides the interface to the supply and provides various protection circuits for your laser diode.

II. Pulsing Characteristics

The rise and fall times of LDQCW pulses are a compromise between speed and minimization of overshoot. Figure 3 shows a typical rise time for an LDQCW.

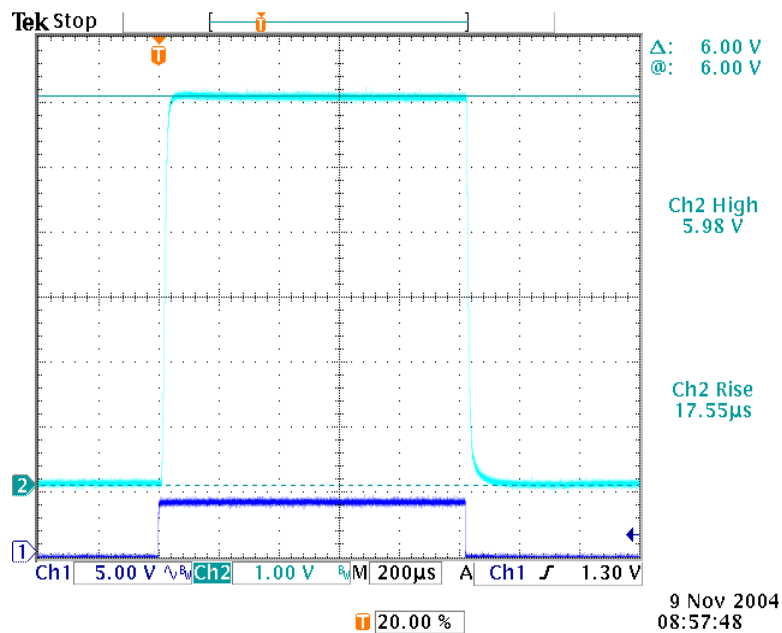

Figure 3 -Typical Rise/Fall Time

This waveform shows a rise/fall time of less than 20usec.

III. Supply Interface Connections

The programming, monitoring and control functions LDQCW Interface as shown below. Refer to Section VI below for a simple laser setup.

LDQCW-250/600-XX-YY Interface Connector Type: 15 pin D-sub Female (sockets)

Pin	Description
1	Pulsing Input: (Input, TTL) This signal is a TTL input for pulsing the system. System delivers pulses of current with output current levels as programmed on Pin 6
2,3,8	GND
4	Temp Fault: (Output, TTL) When the internal temperature on main heat sink has exceeded a safe operating temperature, the output is disabled and this fault is transmitted. Temp Fault output is TTL high.
5	Iout Monitor: (Output) 0 - 10V = Ioutmax Note:3
6	Iprogram(+): (Input) 0 - 10V = Ioutmax Note:3 Note: Accuracy will be compromised when operating below 30% of the maximum value
7	Poor load match: (Output, TTL) When the voltage compliance of the diode laser load is not within 80% to 100% of the maximum rated voltage compliance of the unit, the output is disabled and this fault is transmitted. This fault may be reset three times. If the fault persists after three resets, the unit will disable the output until AC power is removed and applied again. Fault output is TTL high.
11	+15V @0.25A (output) Auxiliary +15V power supply for user. Up to +0.25A output current available.
12	Ready Status: (Output, TTL) When the system has been Enabled and no faults are present, this signal is transmitted. When system is ready, signal is a TTL high.
13	No connection
14	Enable: (Input, TTL) A TTL high level signal enables system operation. The Enable is a soft start system turn on and should not be used for pulsing. If the system is free of faults, a Ready Status high signal is transmitted and system is ready to pulse.
15	-15V @0.25A (output) Auxiliary -15V power supply for user. Up to -0.25A output current available.

Note:1 - Figure 1, Section I, shows the impedance characteristics of each connection.

Note:2 - TTL implies 5 volt logic level.

Note:3 - Each supply is calibrated to the specified current XX. Below are some scale factors:

XX - Ioutmax	Scale Factor
200 Amps	20.0 Amps per Volt
160 Amps	16.0 Amps per Volt
160 Amps	16.0 Amps per Volt
140 Amps	14.0 Amps per Volt
120 Amps	12.0 Amps per Volt
110 Amps	11.0 Amps per Volt
100 Amps	10.0 Amps per Volt
70 Amps	7.0 Amps per Volt
60 Amps	6.0 Amps per Volt
50 Amps	5.0 Amps per Volt
41 Amps	4.1 Amps per Volt

IV. Operation of the LDQCW

Warning – Voltage Compliance Requirement

Each LDQCW is custom configured to deliver pulses of current into an array requiring a predefined compliance voltage. The LDQCW will not operate properly when connected to an array that requires more than +105% or less than 75% of the rated voltage of the unit. See the Serial Number label of the unit for the compliance voltage rating. When driving a load requiring more than 105% of the rated voltage of the unit, output current will not reach the programmed value. When driving a load requiring a voltage less than 75% of the specified output voltage, the unit will shut off to protect internal circuitry from over-temperature conditions (see Pin 7 of the Interface)

Warning – Output Floating

The output of the LDQCW is floating and therefore, neither side of the laser diode is allowed to be connected to the same ground as signal ground (Program, Monitor).

1. Connect diode laser load to power supply. A custom strip line cable has been supplied to minimize inductance. Please note the cable is marked with (+) and (-) labels.
2. Connect appropriate interface to LDQCW Interface Connector. Make sure **Iprogram(+)**, pin 6, is set to 0.0V.
3. Connect AC input power cables. **Make sure AC input power is OFF.** LDQCW models accept input voltage between 90-264VAC.
4. Apply AC input power to unit. After a few seconds the cooling fan should begin to operate.
5. Set **Iprogram(+)**, Pin 6 of the interface connector, This signal is the 0-10V program which will program the output current level. Calibration is set so that 0-10V = 0 – $I_{out_{max}}$.
6. **Enable** the output by applying a TTL level high signal to pin 14 of the interface connector. The **Enable** control checks for faults and prepares the system for pulsing.
7. Pulse the unit via the **Pulsing Input** control, pin 1. Maximum pulse widths should not be greater than 1msec. The amplitude of the pulses will be determined via the analog **Iprogram(+)** signal. Maximum average power delivered to the load should be less than the rated power capability of the unit.

V. Unit Faults

The unit is designed to monitor various faults such as

- **Temp Fault: (Output, TTL, Pin 4)** When the temperature of the internal heat sink has exceeded a safe operating level, the system is shut off and this fault is transmitted. Fault output is TTL high. Fault can be cleared by setting the **Enable**, pin 14, to TTL low and then high.
- **Poor load match: (Output, TTL, Pin 7)** When the voltage compliance of the diode laser load is below 75% of the specified compliance voltage of the unit, the output is disabled and this fault is transmitted. Fault output is TTL high. This fault may be cleared via the **Enable** signal three times. If the fault persists after three resets, the unit will disable the output until AC power is removed and applied again.

VI. Simple Laser Setup

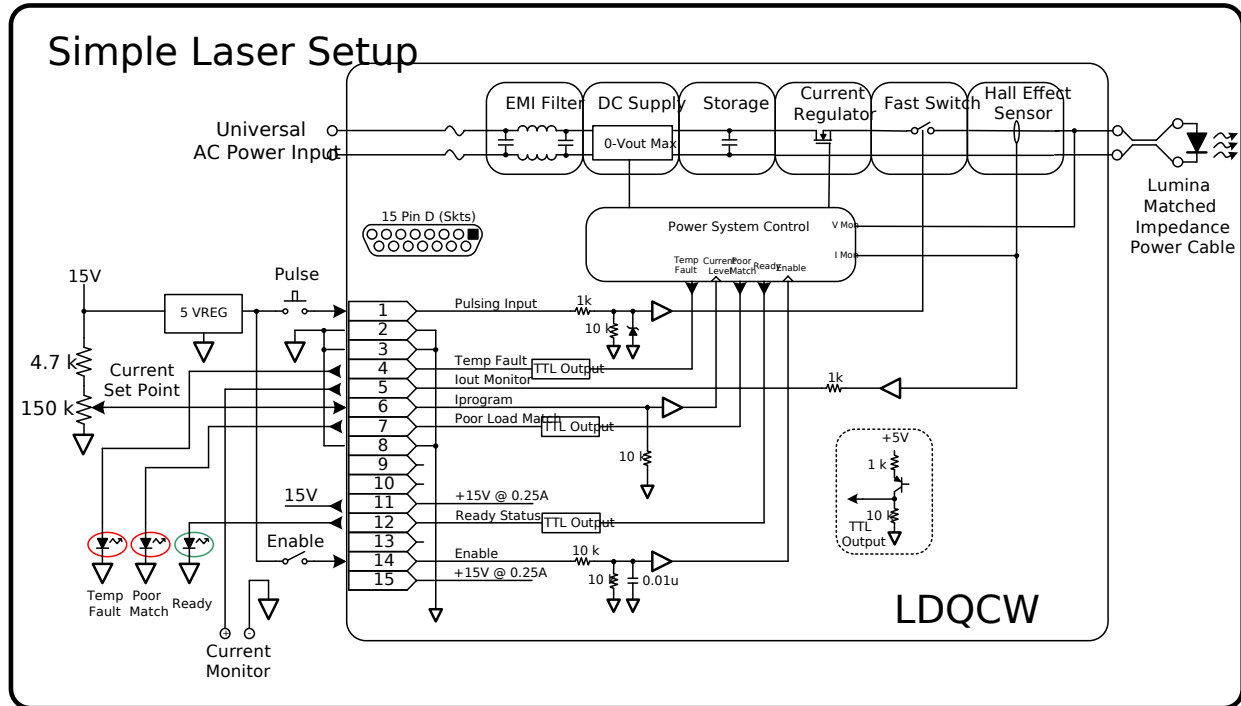

Figure 4 - Simple Laser Setup

VII. System Integration Notes

- When connecting to the LDQCW consider the input and output impedance of the interface connections. Refer to Section V, Figure 4.
- The performance of the rise time is determined by the impedance of the cabling to the laser. Fast rise times must take into consideration the inductance and capacitance of the wires carrying the current to the Laser. The Lumina Power high current matched output cable provided should be used to meet the specified characteristics.
- It is recommended that reverse protection be placed at the laser diode due to potential issues that may be introduced by cabling and other system integration events.

VIII. Operating Voltage

Each LDQCW is configured to the customer's specification at the factory. Operating the LDQCW at or near the configured voltage is important for thermal consideration of the power supply.

Example 1:

150 amps are needed to drive an array of 10 diodes. Taking into consideration the approximate voltage drop on the wires to the laser and the voltage drop of the lasers a 22 volt unit would be required. For this the customer orders a LDQCW-600-150-22, with the operating parameters in Table 1 below.

The factory configures the internal DC supply to a minimum of 26 volts based on the 22 volt specified output. This allows the LDQCW to provide regulation through the High Power Linear regulator, see Figure 2 in Section I. The power dissipation in the supply is shown in Table 1.

Requirements		Power Output	Linear Regulator Dissipation
LDQCW-600-150-22		$P_{out} = I_{out} * V_{load}$ $P_{out} = 150A * 22V$ $P_{out} = 3.3 \text{ kW}$	$P_{reg} = I_{out} * V_{reg}$ $P_{reg} = I_{out} * (V_{dc} - V_{load})$ $P_{reg} = 150A * (26 - 22)V$ $P_{reg} = 600W$ With a duty cycle of 18% the average power will be 108 W, This should be no problem for the supply.
Max Avg Power	600W		
Max Iout	150A		
Compliance Voltage	22 Volts		
Max Pulse Width	1 msec		
Max Rep Rate	180 Hz		

Table 1 – Linear Power Regulator Dissipation

Example 2:

A third example shows what happens when the customer above uses the same LDQCW to drive a smaller diode array. This is a common misunderstanding between current sources and standard DC voltage supplies. The customer used this supply to drive an array of 10 diodes and now connects it up to ‘only’ an array of 5 laser diodes, using the rationalization: less should be easier. Table 2 shows the resulting error.

Requirements		Power Output	Linear Regulator Dissipation
LDQCW-600-150-22		$P_{out} = I_{out} * V_{load}$ $P_{out} = 150A * 11V$ $P_{out} = 1.65 \text{ kW}$	$P_{reg} = I_{out} * V_{reg}$ $P_{reg} = I_{out} * (V_{dc} - V_{load})$ $P_{reg} = 150A * (26 - 11)V$ $P_{reg} = 2.25 \text{ kW}$
Max Avg Power	600W		
Max Iout	150A		
Compliance Voltage	22 Volts		
Max Pulse Width	1 msec		
Max Rep Rate	180 Hz		

Table 1 – Low Load Voltage

In this case, enabling the supply would result in a Poor Match Fault. The Poor Match Fault is triggered when the linear regulator sees greater than 25% of the compliance voltage. This preventative fault, however, does not eliminate the possibility of creating a situation where the supply will reach a Temperature Fault. The supply is a component in the laser system and proper engineering of the complete system must be considered. If peak power levels exceeded the safe operating area of the linear regulator, the device will fail. It is always best to operate the supply near the specified Compliance Voltage.

[Lumina Power, Inc.](http://www.luminapower.com)
[26 Wardhill Avenue, Bradford, MA 01923](http://www.luminapower.com)
 Ph: 978-241-8260 Fx: 978-421-8262
www.luminapower.com
Sales@luminapower.com